

beyma //

8NMF

NMF SYSTEM SERIES

8NMF
T-25M



ENCLOSURE RECOMMENDED DESIGN

www.beyma.com



TECHNICAL SPECIFICATIONS

Frequency response (+/-3dB)	55Hz-22KHz
Usable bandwidth (-10dB)	42Hz-30KHz
Maximum SPL(*)	107dB
Sensitivity 1W@1m	88dB
HxV Coverage angle (-6dB)	80°x80°
Transducers LF	8NMF
Transducers HF	T-25M
AES Power Handling	200W
Nominal impedance	8Ω
Connectors	2xNL4
Box dimensions (**)	235 x 400 x 264 (Birch Plywood 15/9mm)

(*) Peak level at 1m under free field conditions usin pink noise with 6dB crest factor

(**) All dimmensions in millimeters



PRESSETS

8NMF	f(Hz)	Q	Gain(dB)
-	-	-	-
LIMITER	Thres (dBu)	Attack (ms)	Release (ms)
PEAK	5.3	16	256

* for 32dB gain amplifier
 *frequency response graph CD151PK with T25M

FREQUENCY RESPONSE

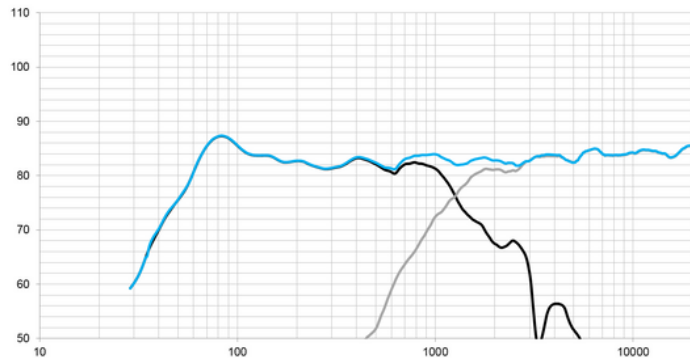

PASSIVE CROSSOVER DESIGN

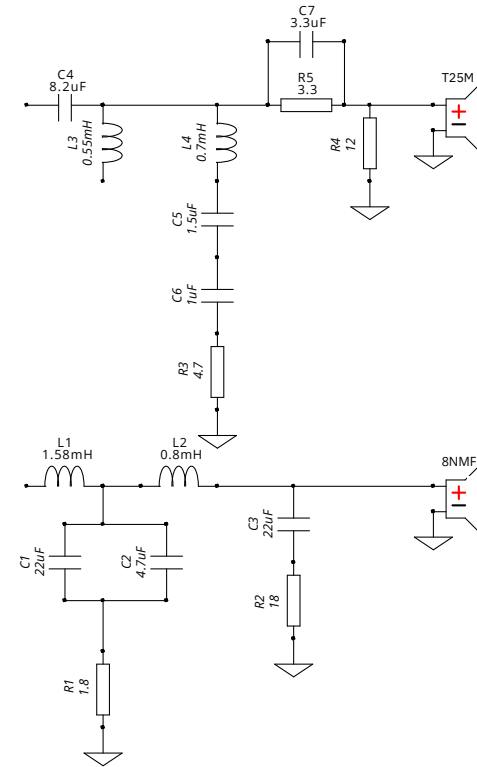

IMPEDANCE

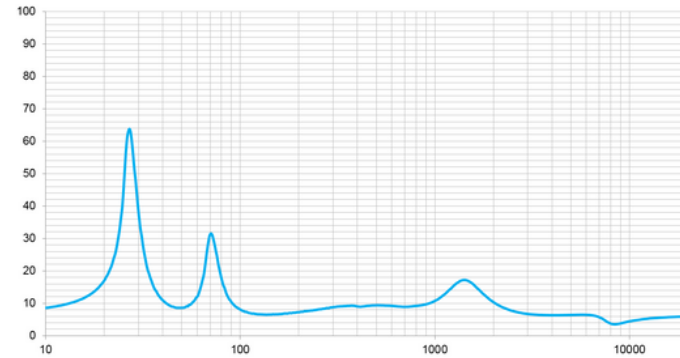



GENERAL VIEW WITH COMPONENTS

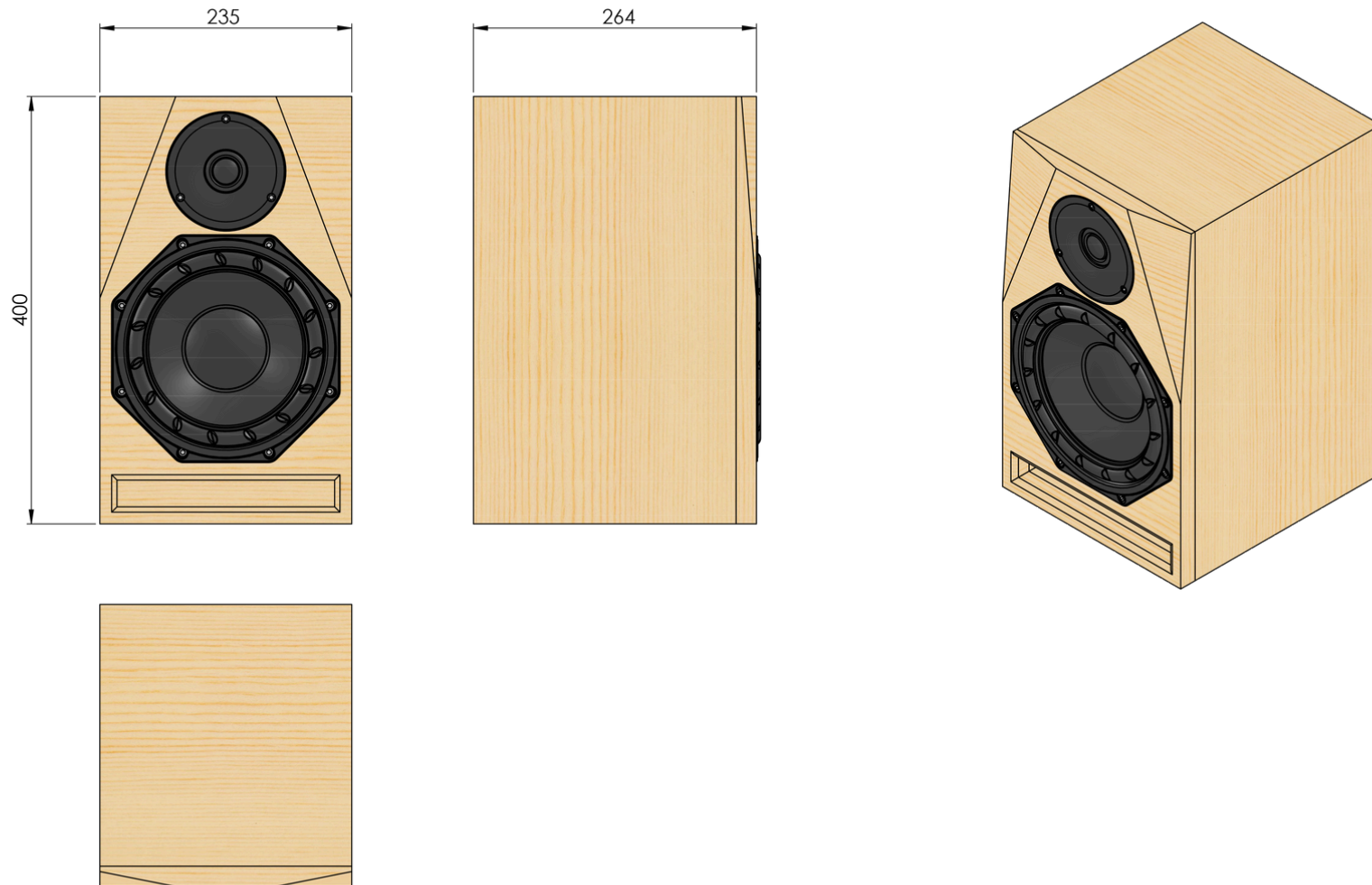



EXPLODED VIEW WITH COMPONENTS

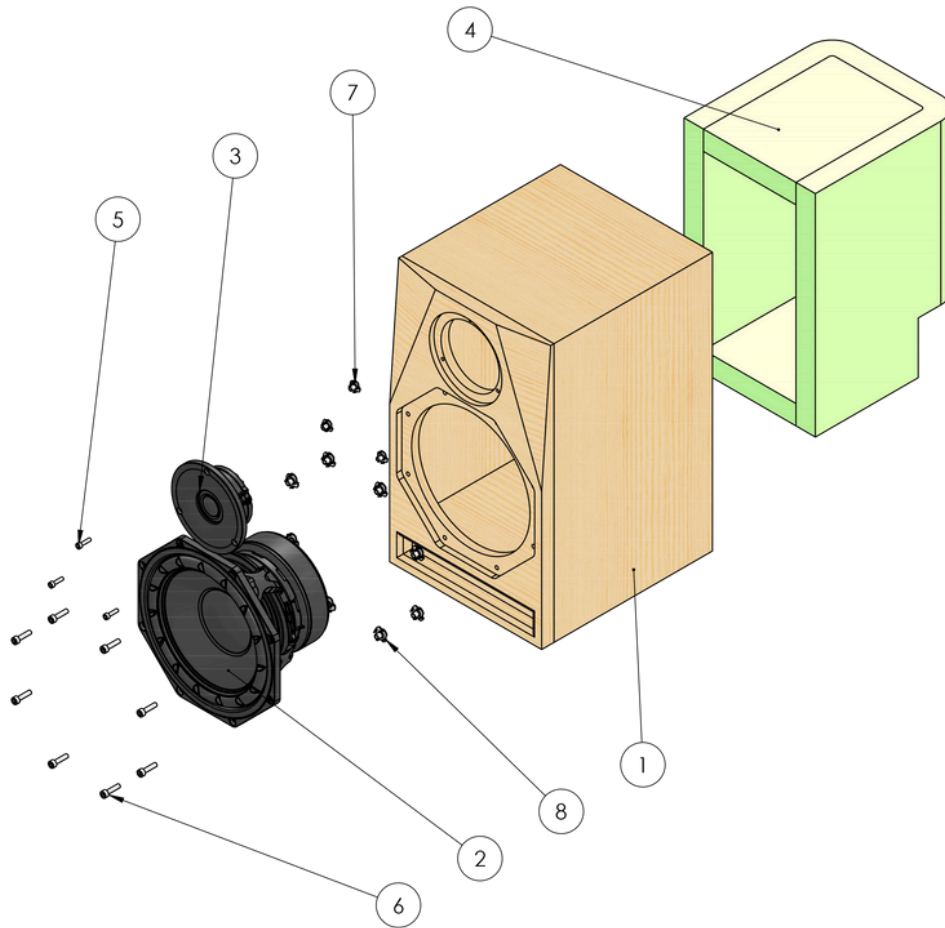

ELEMENT NUMBER	PIECE NUMBER	QUANTITY
1	8NMF	1
2	8NMFW	1
3	T-25M	1
4	DAMPING MATERIAL	1
5	SCREW DIN 912 M4x15	3
6	SCREW DIN 912 M5x20	8
7	NUT DIN1624 - M4	3
8	NUT DIN1624 - M5	8



GENERAL VIEW

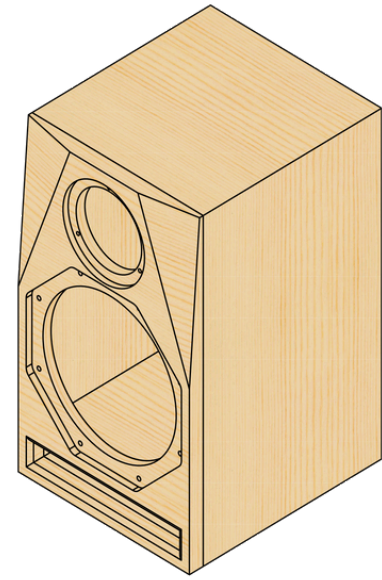
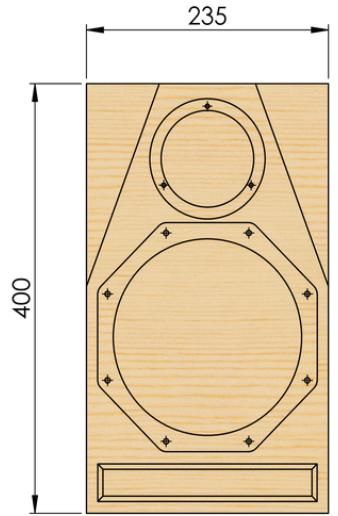



EXPLODED VIEW

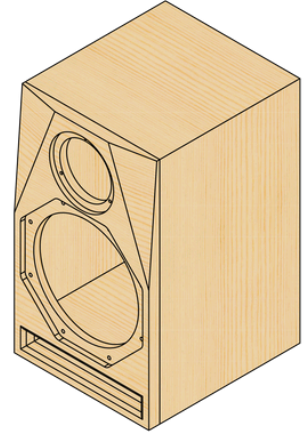
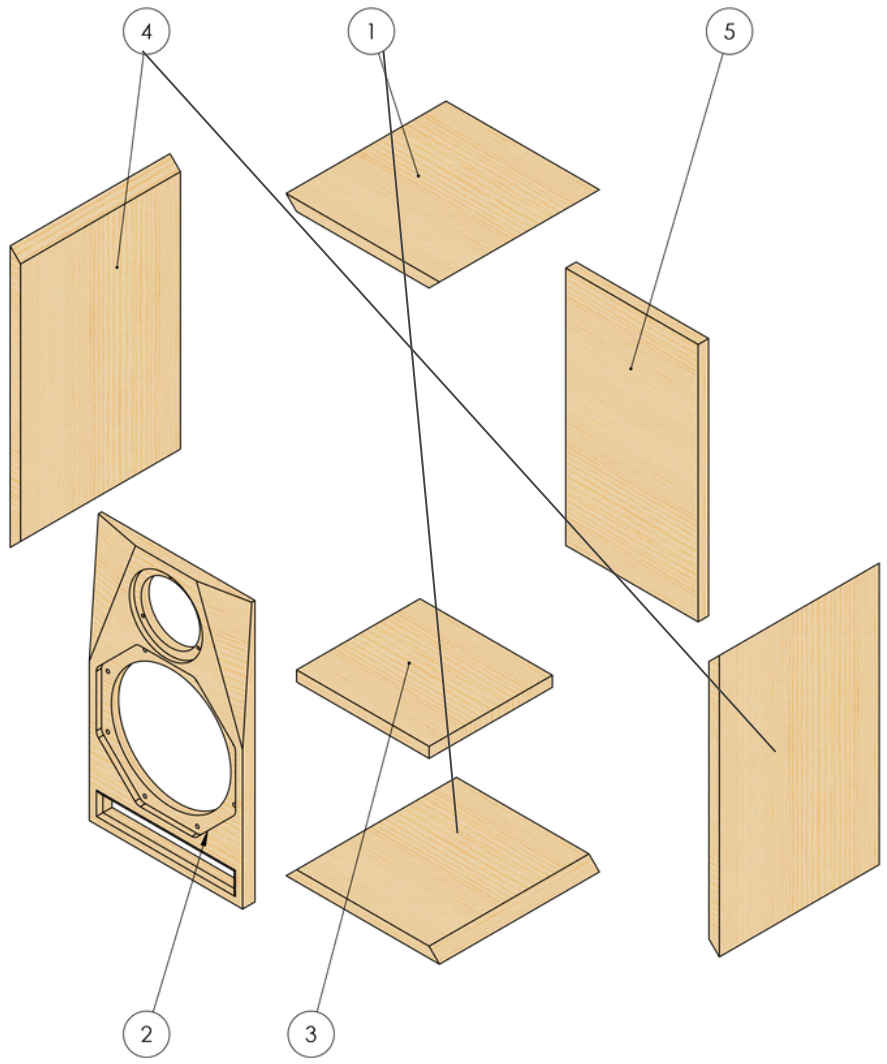

ELEMENT NUMBER	PIECE NUMBER	QUANTITY
1	TOP & BOTTOM PARTS	2
2	FRONT PANEL	1
3	REFLEX	1
4	SIDE	2
5	BACK PANEL	1



TOP & BOTTOM PARTS

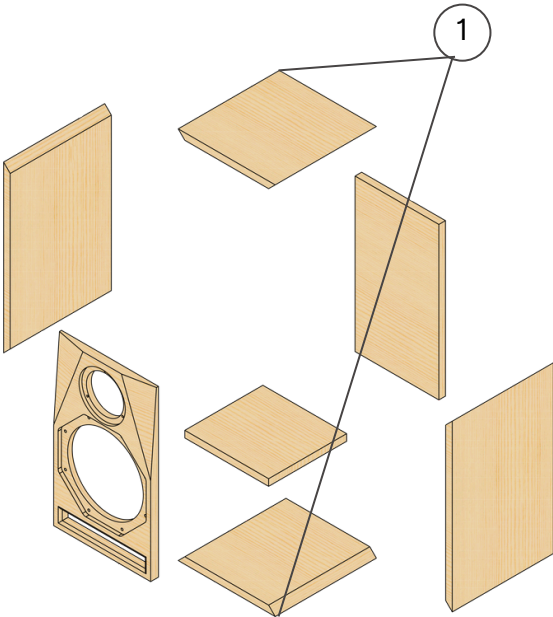
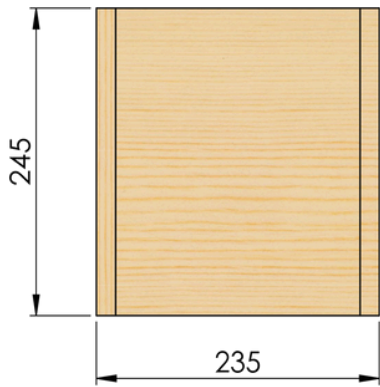
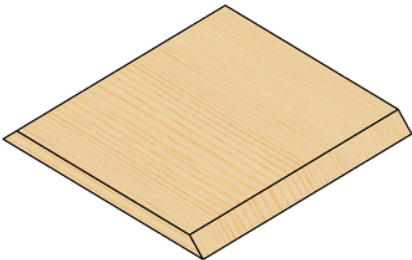
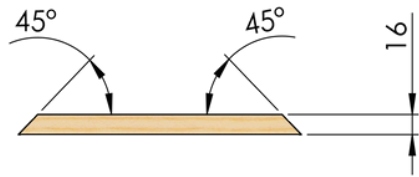



FRONT PANEL

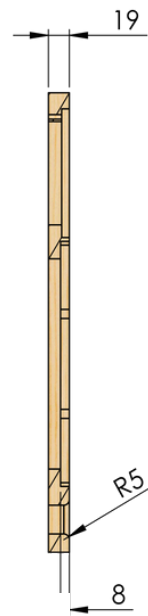
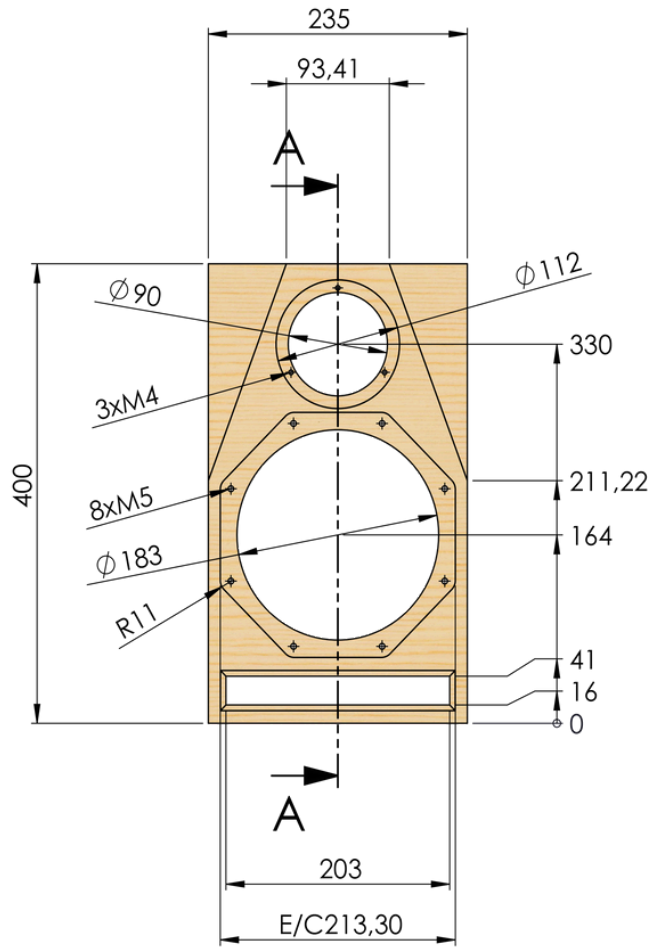

SECTION A-A

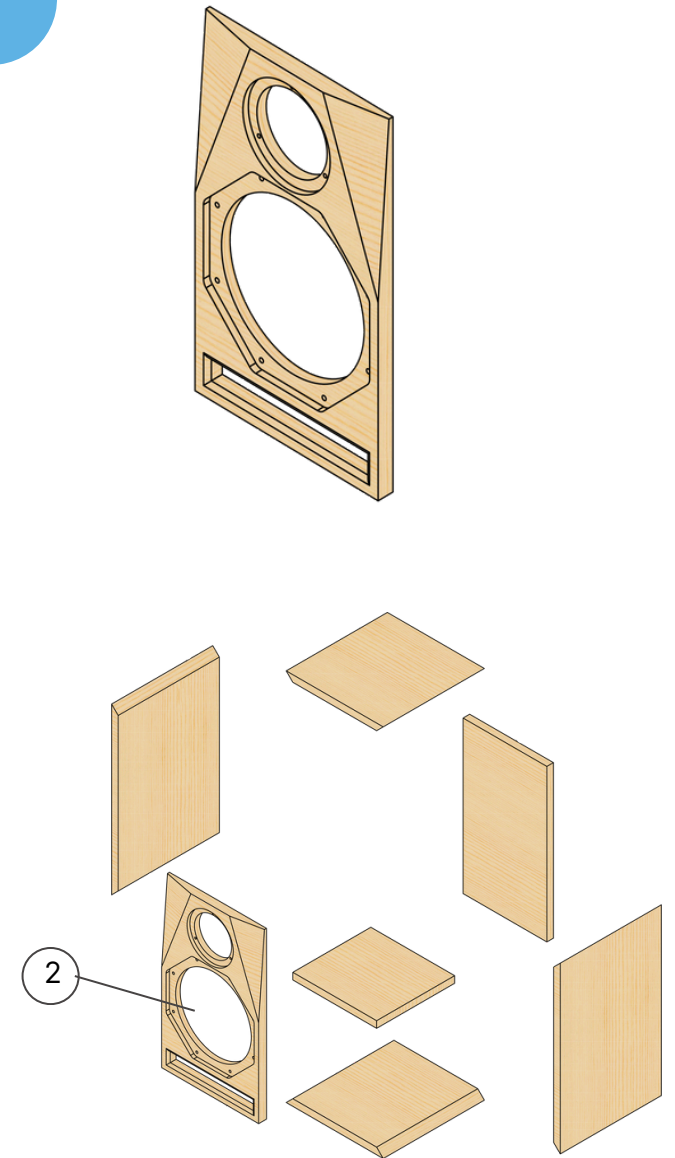



REFLEX

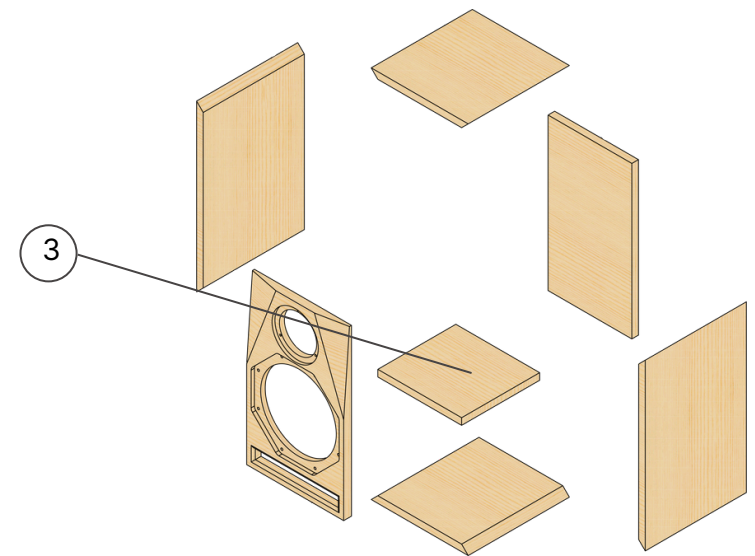
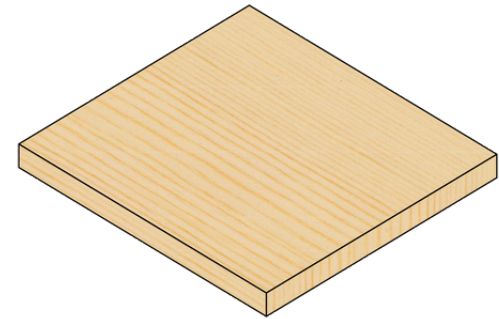
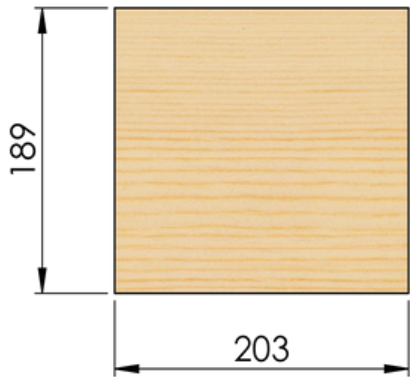



SIDE

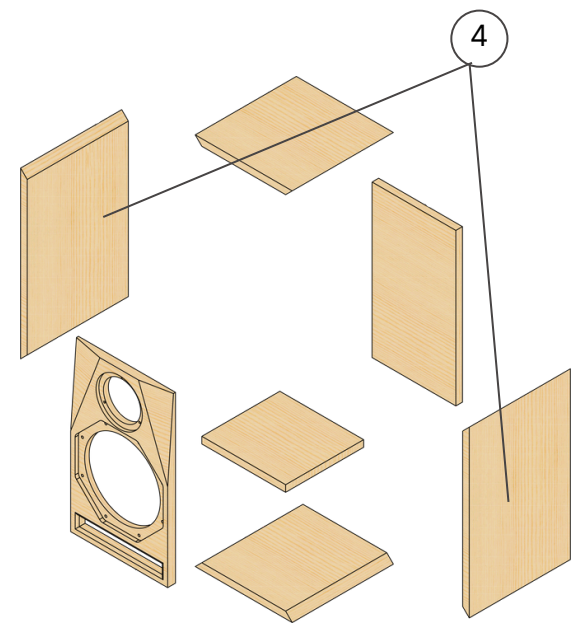
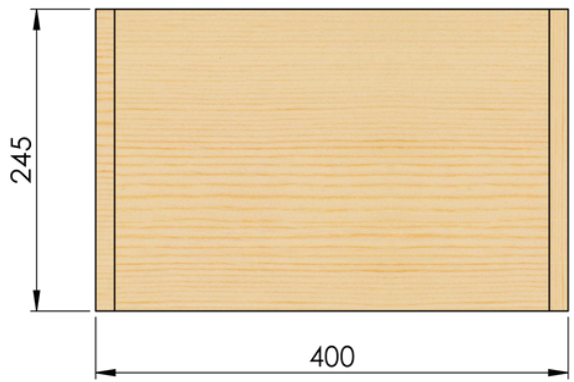
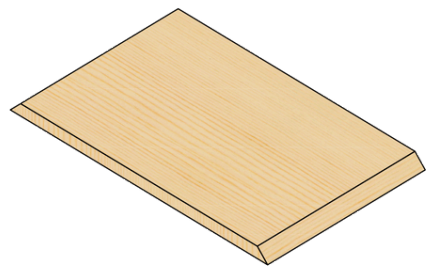
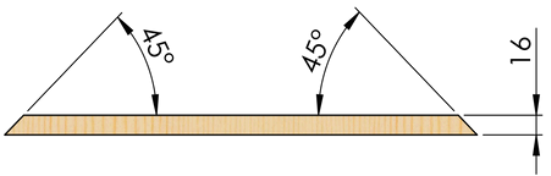



BACK PANEL

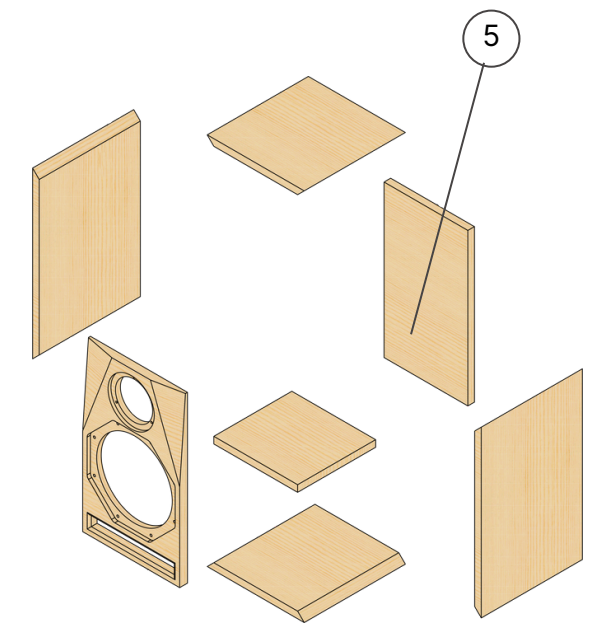
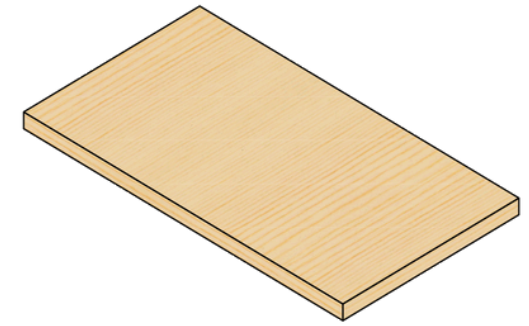
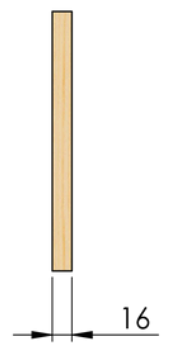

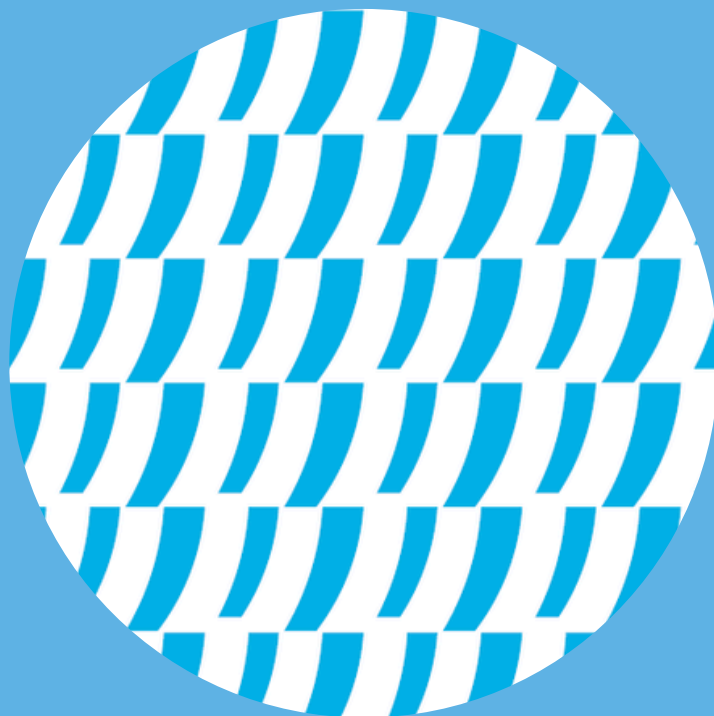

LET'S TALK

www.beyma.com