

FR-10MC

FULL RANGE 2 WAY SYSTEM 10"

10MC500 / 10MCS500

CD171Fe

TD-164P

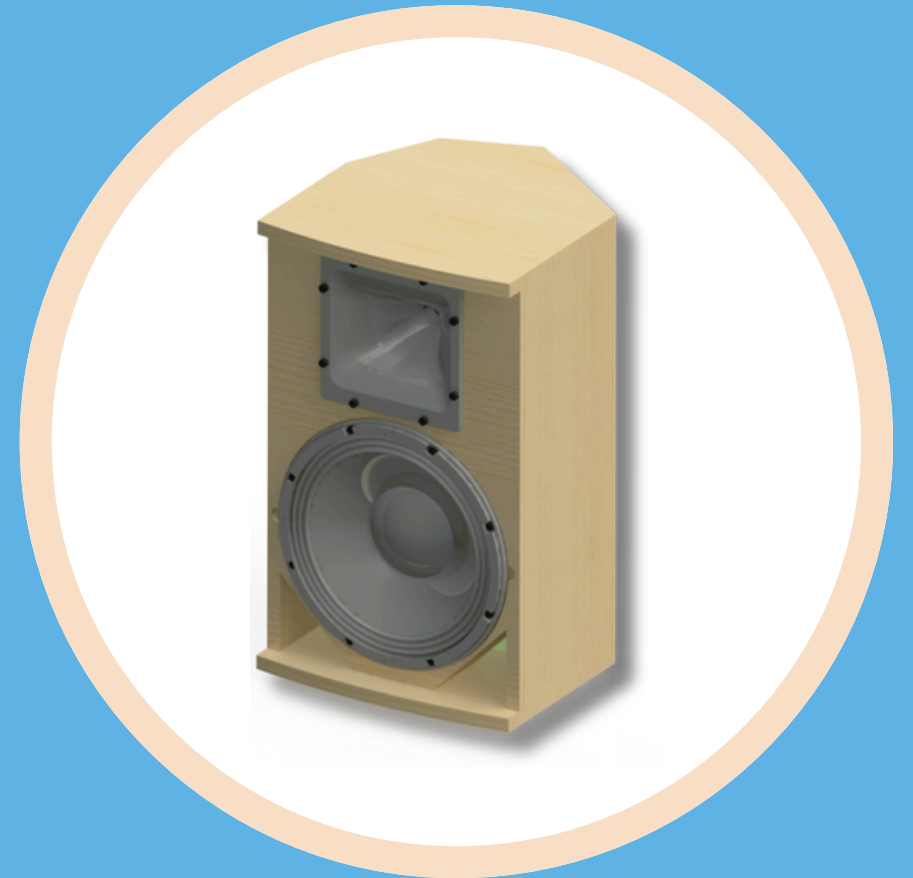

ENCLOSURE RECOMMENDED DESIGN

www.beyma.com



TECHNICAL SPECIFICATIONS

Frequency response (+/-3dB)	65Hz-20KHz
Usable bandwidth (-10dB)	50Hz-22KHz
Maximum SPL(*)	125dB
Sensitivity 1W@1m	92dB
HxV Coverage angle (-6dB)	60°x40° rotatable
Transducers LF	10MC500/ 10MCS500
Transducers HF	CD171Fe
AES Power Handling	500W
Nominal impedance	8Ω
Connectors	2xNL4
Box dimmensions (**)	290 x 480 x 312 (Birch Plywood 15/9mm)
(*) Peak level at 1m under free field conditions usin pink noise with 6dB crest factor	
(**) All dimmensions in millimeters	





PRESSETS

FR-10MC	f(Hz)	Q	Gain(dB)
-	400	2	-3,5
-	1574	0,4	-2,5
-	1080	5	-2,5
-	3000	1	-5
LIMITER	Thres (dBu)	Attack (ms)	Release (ms)
PEAK	9,2	8	128

* for 32dB gain amplifier
* frequency response graph CD171PK with TD164P horn

PASSIVE CROSSOVER DESIGN

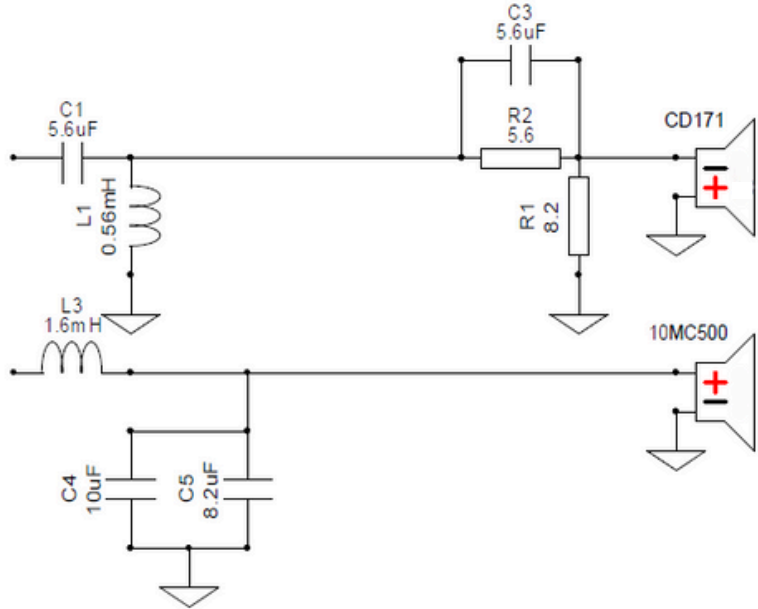

FREQUENCY RESPONSE

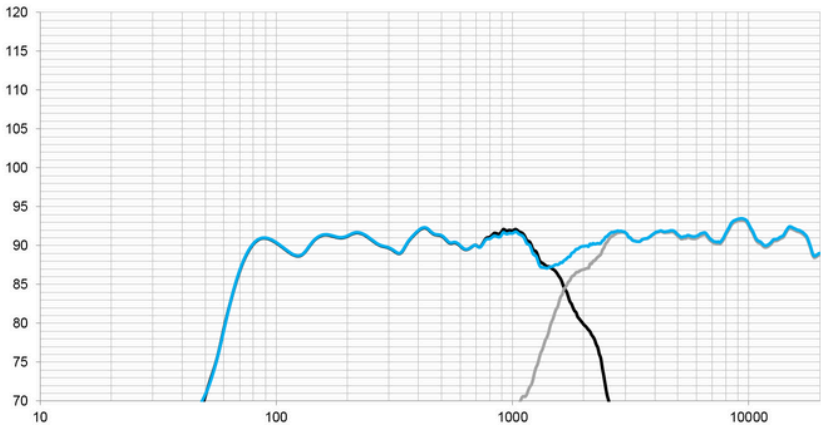

IMPEDANCE

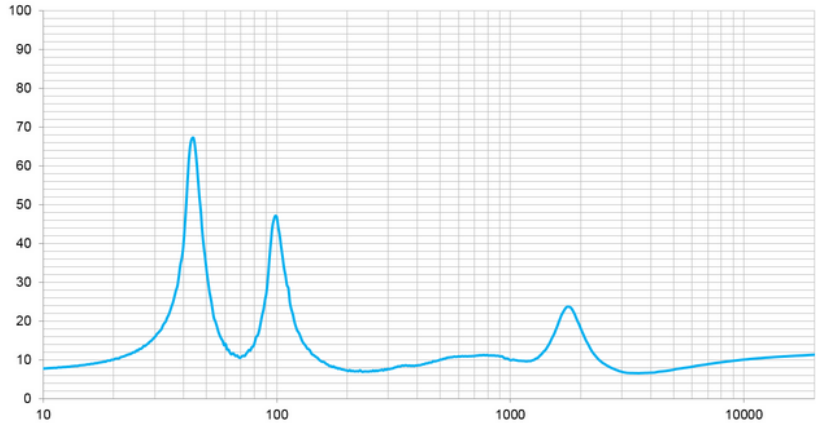



GENERAL VIEW WITH COMPONENTS

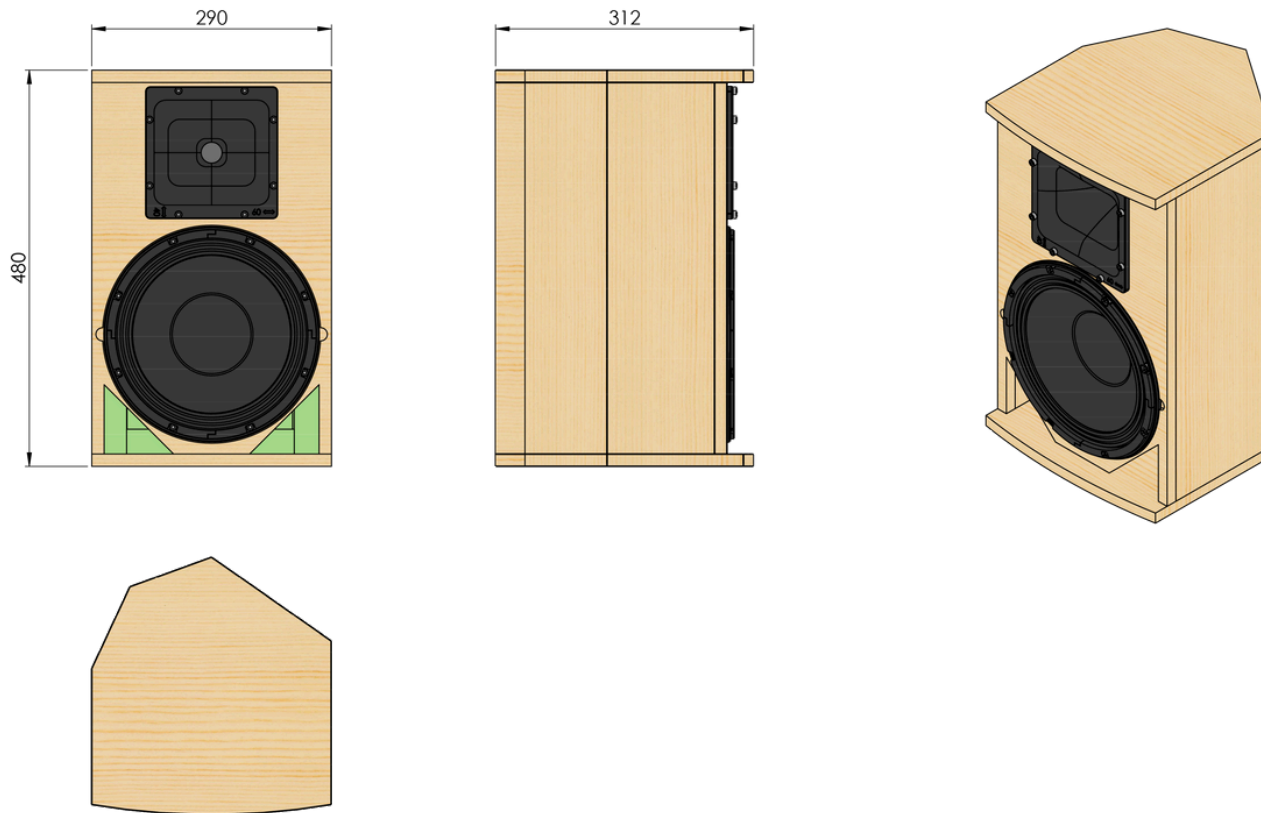



EXPLODED VIEW WITH COMPONENTS

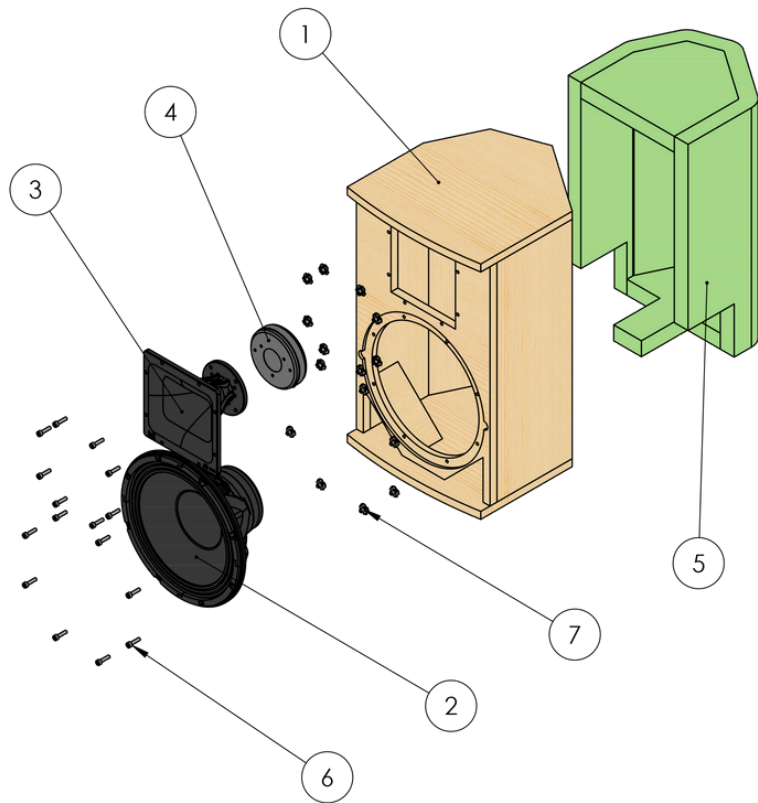

ELEMENT NUMBER	PIECE NUMBER	QUANTITY
1	FR-10MC	1
2	10MC700ND	1
3	TD164P	1
4	CD171Fe-PT & PK	1
5	DAMPING MATERIAL	1
6	SCREW DIN 912 M5x20	16
7	NUT DIN1624 - M5	16



GENERAL VIEW

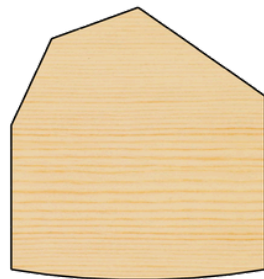
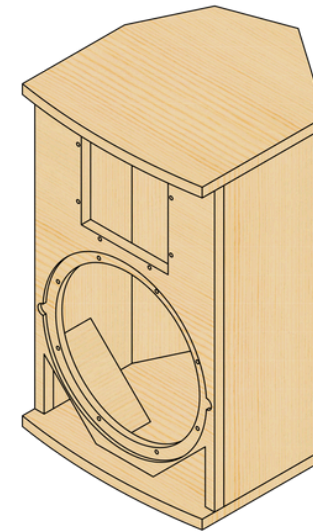
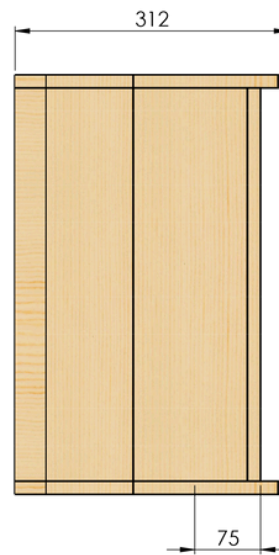
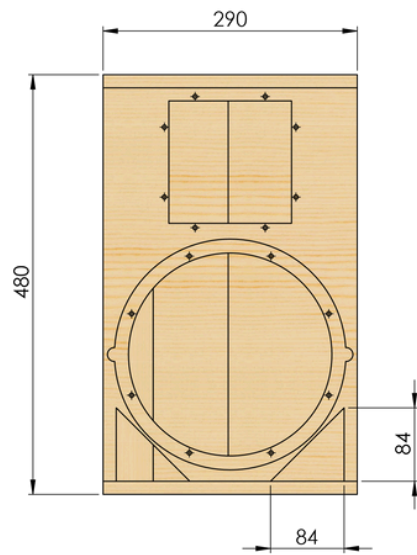



EXPLODED VIEW

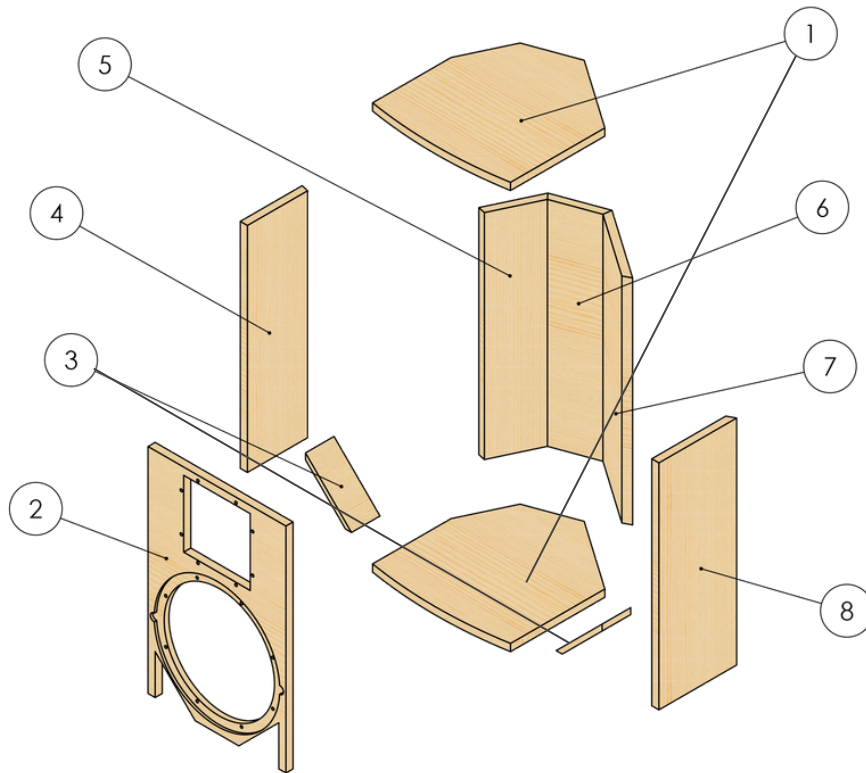
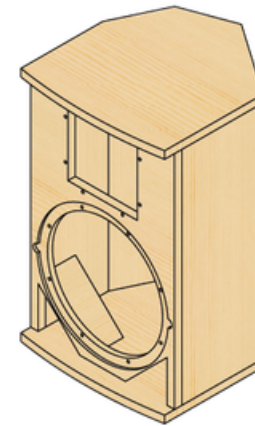

ELEMENT NUMBER	PIECE NUMBER	QUANTITY
1	TOP & BOTTOM PARTS	2
2	FRONT PANEL	1
3	REFLEX	2
4	SIDE_1	1
5	SIDE_2	1
6	SIDE_3	1
7	SIDE_4	1
8	SIDE_5	1



TOP & BOTTOM PARTS

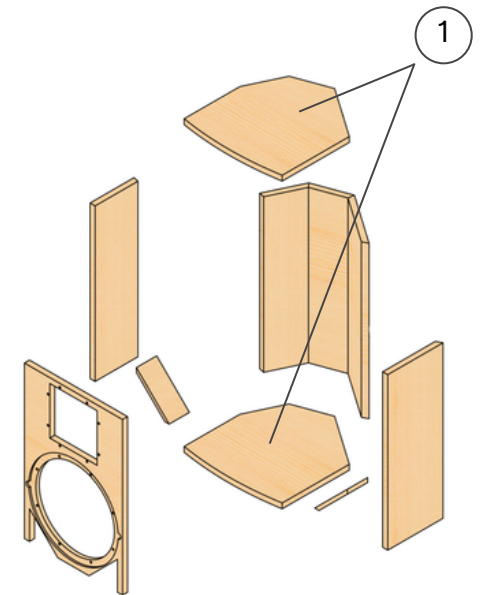
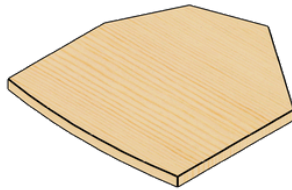
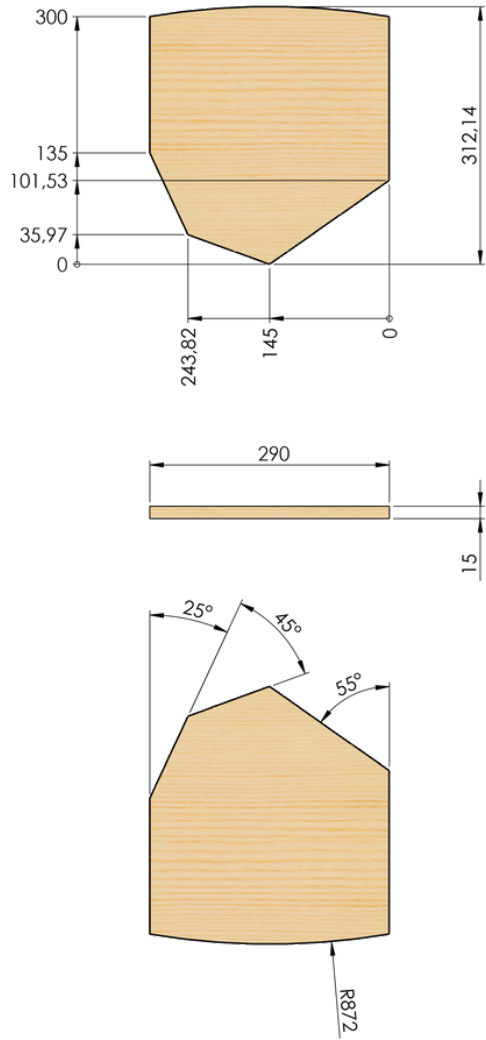



FRONT PANEL

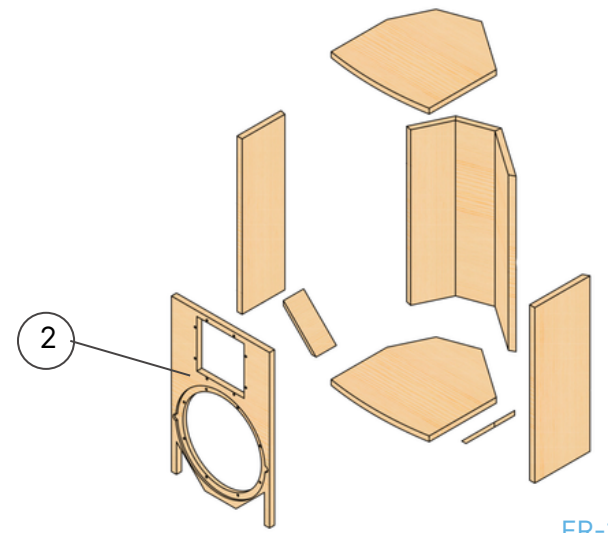
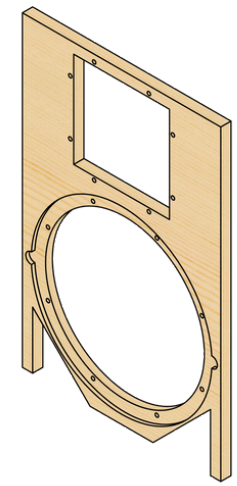
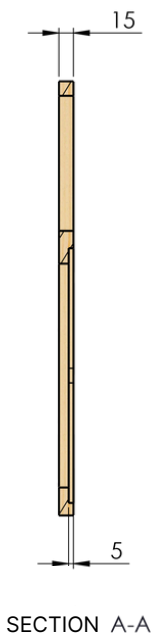
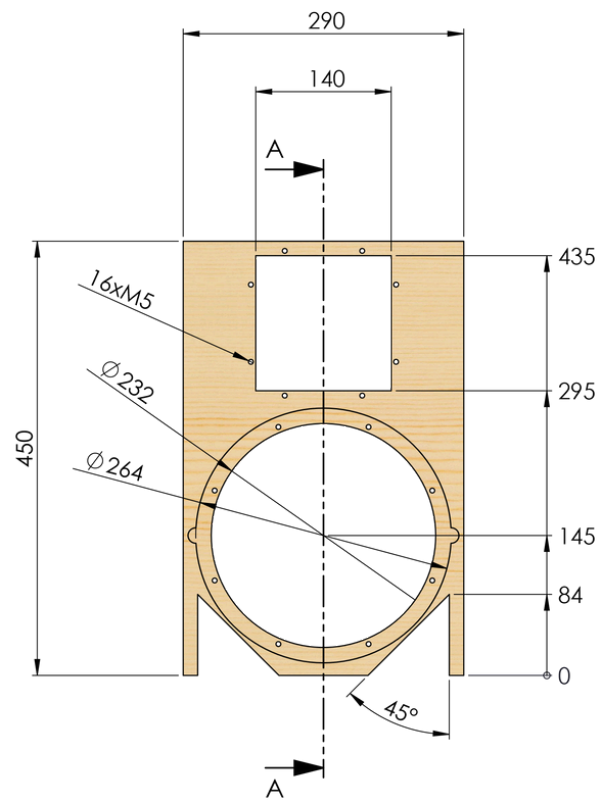



REFLEX

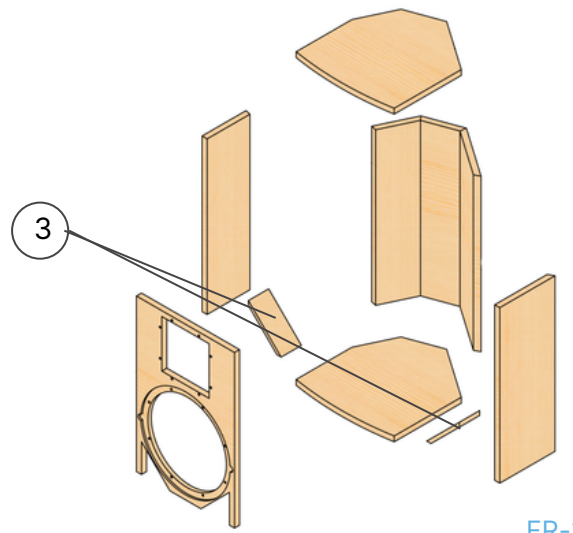
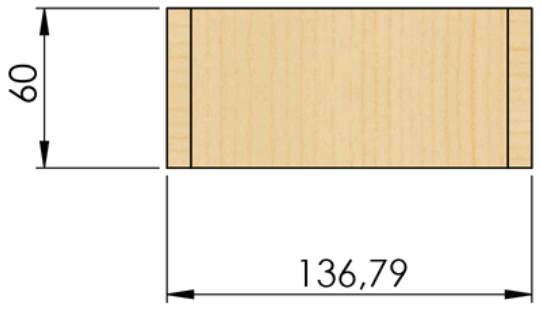
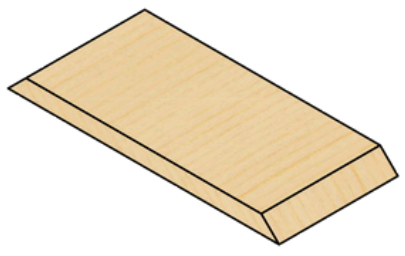
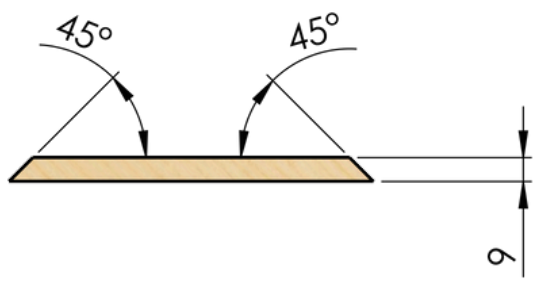



SIDE 1

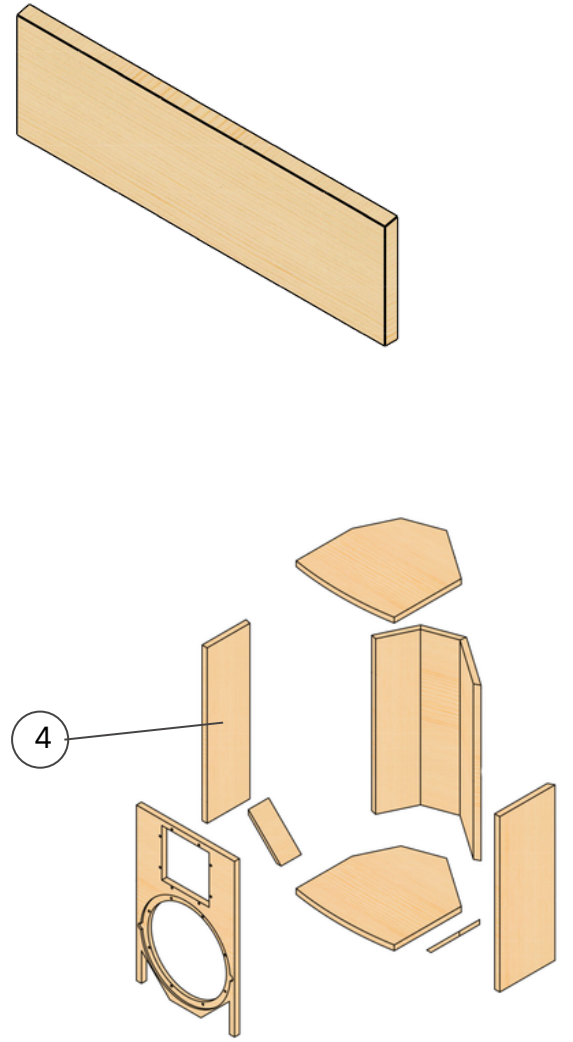
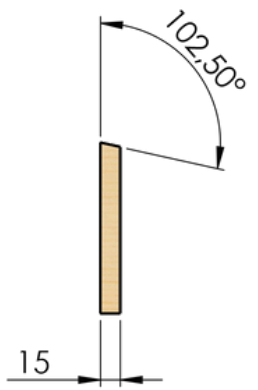



SIDE 2

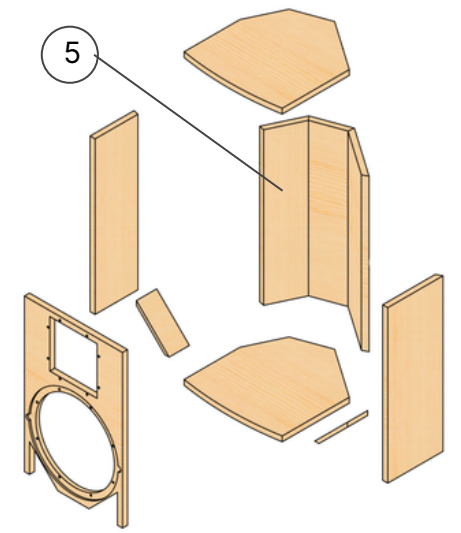
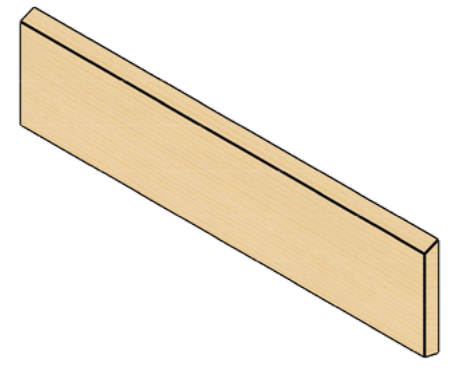
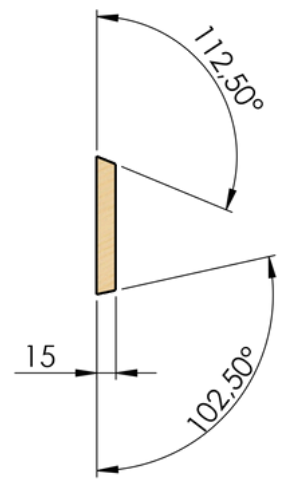



SIDE 3

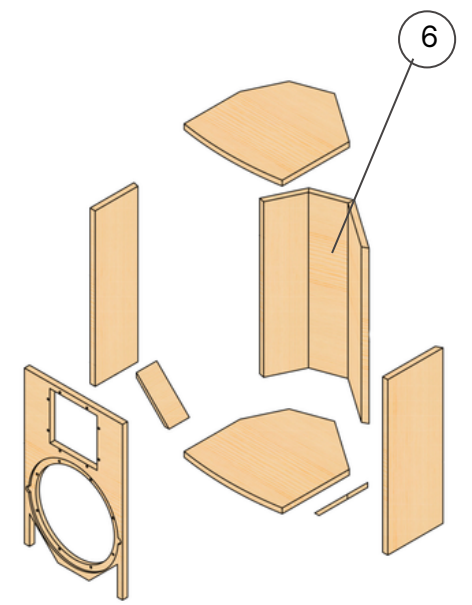
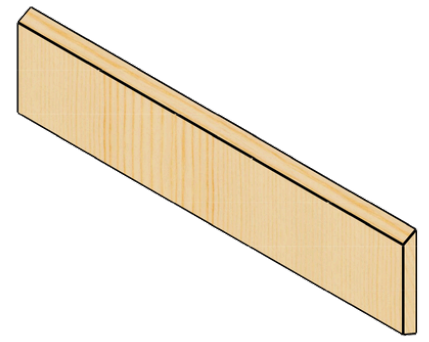
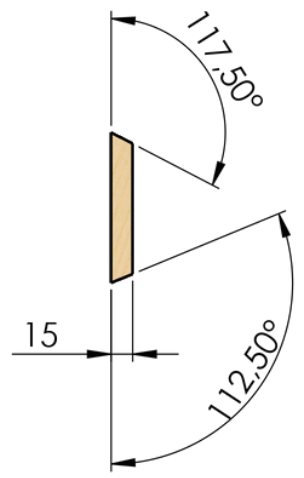



SIDE 4

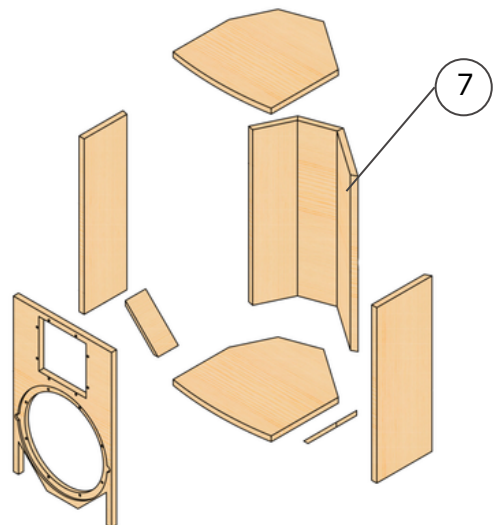
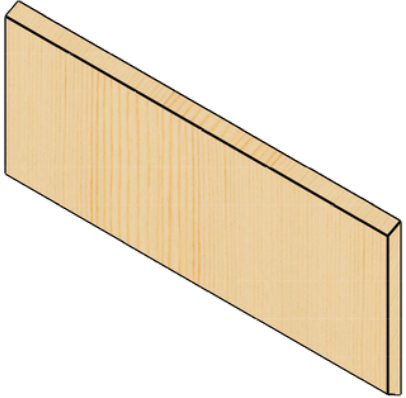
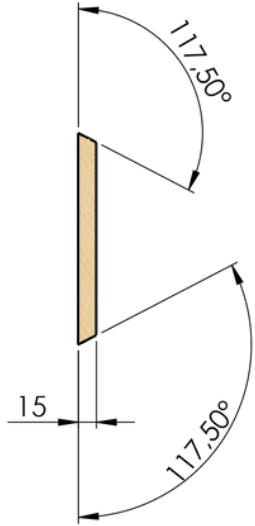



SIDE 5

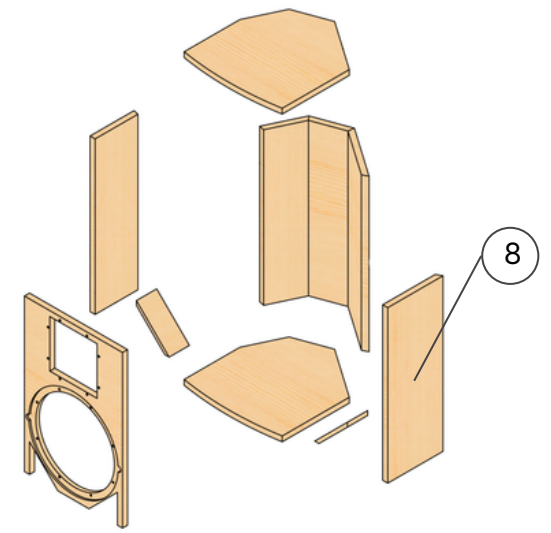
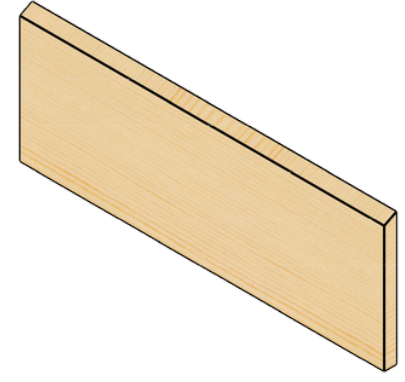
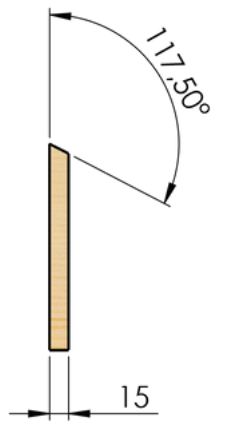
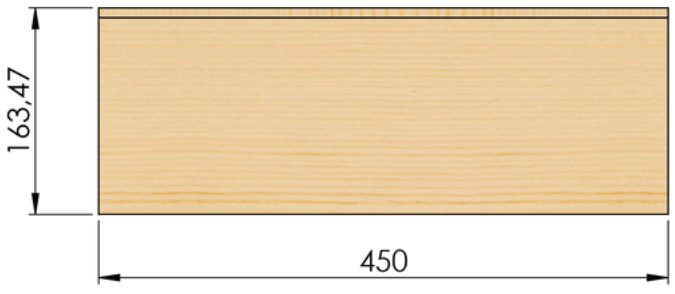

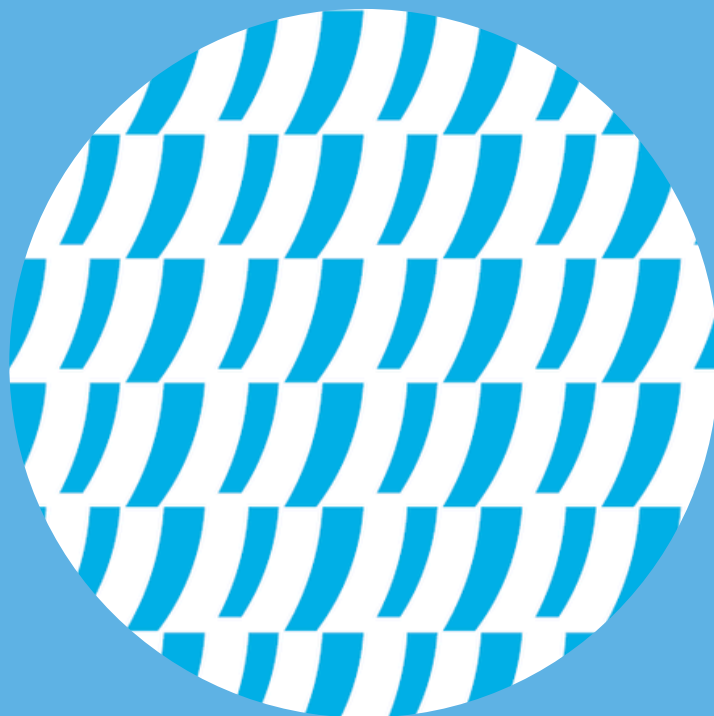

LET'S TALK

www.beyma.com