

FR-12MC HI

FULL RANGE 2 WAY SYSTEM 12"

12MC700ND / 12MCB700

CD314Nd/Fe

TD-365



ENCLOSURE RECOMMENDED DESIGN

www.beyma.com



TECHNICAL SPECIFICATIONS

Frequency response (+/-3dB)	70Hz-18KHz
Usable bandwidth (-10dB)	55Hz-20KHz
Maximum SPL(*)	133dB
Sensitivity 1W@1m	98dB
HxV Coverage angle (-6dB)	60°x50° rotatable
Transducers LF	12MC700ND / 12MCB700
Transducers HF	CD314Nd/Fe
AES Power Handling	700
Nominal impedance	8Ω
Connectors	2xNL4
Box dimensions (**)	340 x 610 x 281.64 (Birch Plywood 15/9mm)

(*) Peak level at 1m under free field conditions usin pink noise with 6dB crest factor

(**) All dimmensions in millimeters

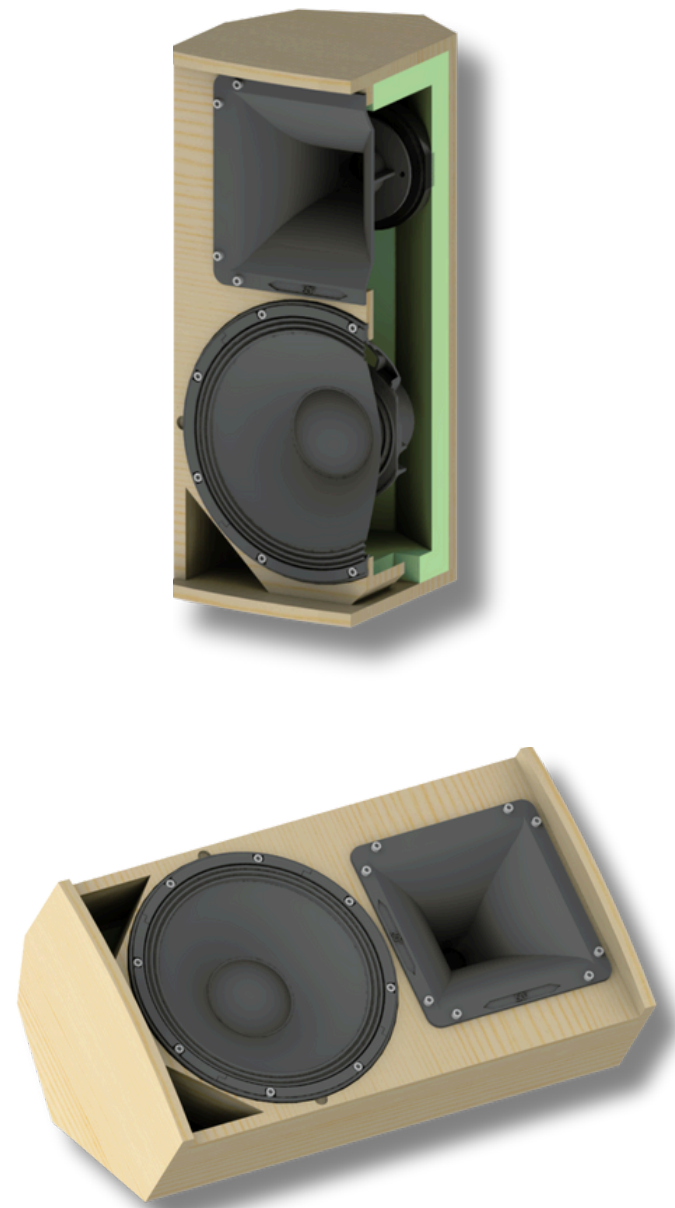



PRESSETS

FR-12MC HI	f(Hz)	Q	Gain(dB)
-	125	1,1	8,5
-	270	3,1	4
-	350	1,6	-5
LIMITER	Thres (dBu)	Attack (ms)	Release (ms)
PEAK	10,7	8	128

* for 32dB gain amplifier
 * frequency response graph CD314Nd/Ti with TD365 horn

PASSIVE CROSSOVER DESIGN

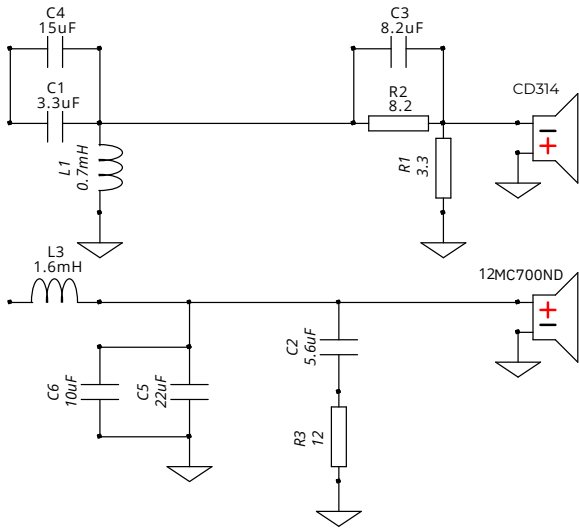

FREQUENCY RESPONSE

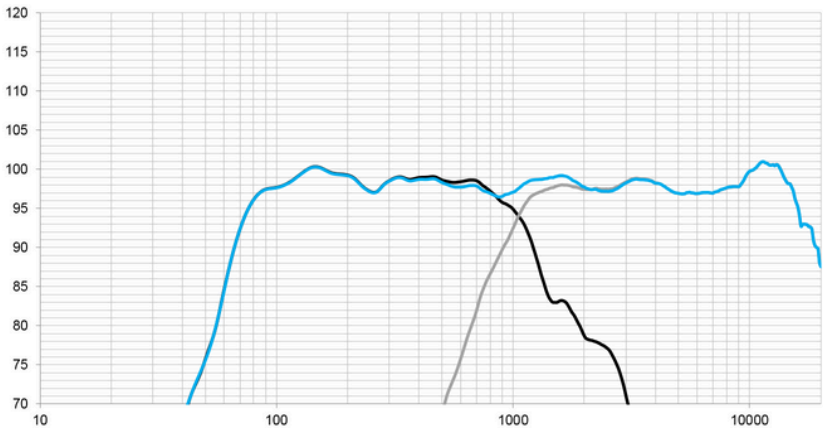

IMPEDANCE

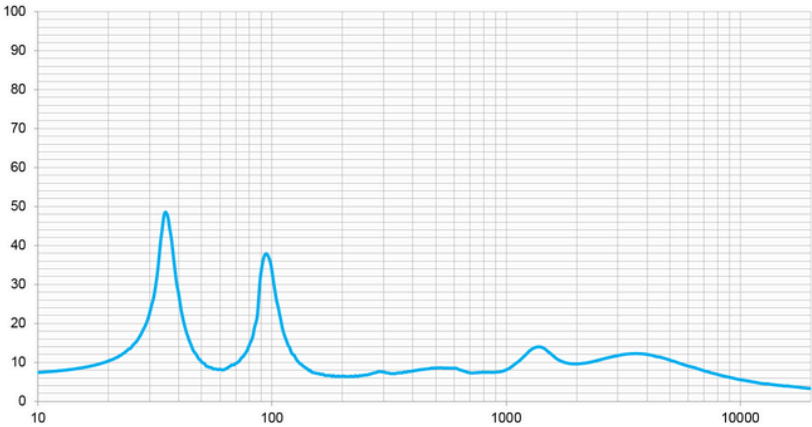



GENERAL VIEW WITH COMPONENTS

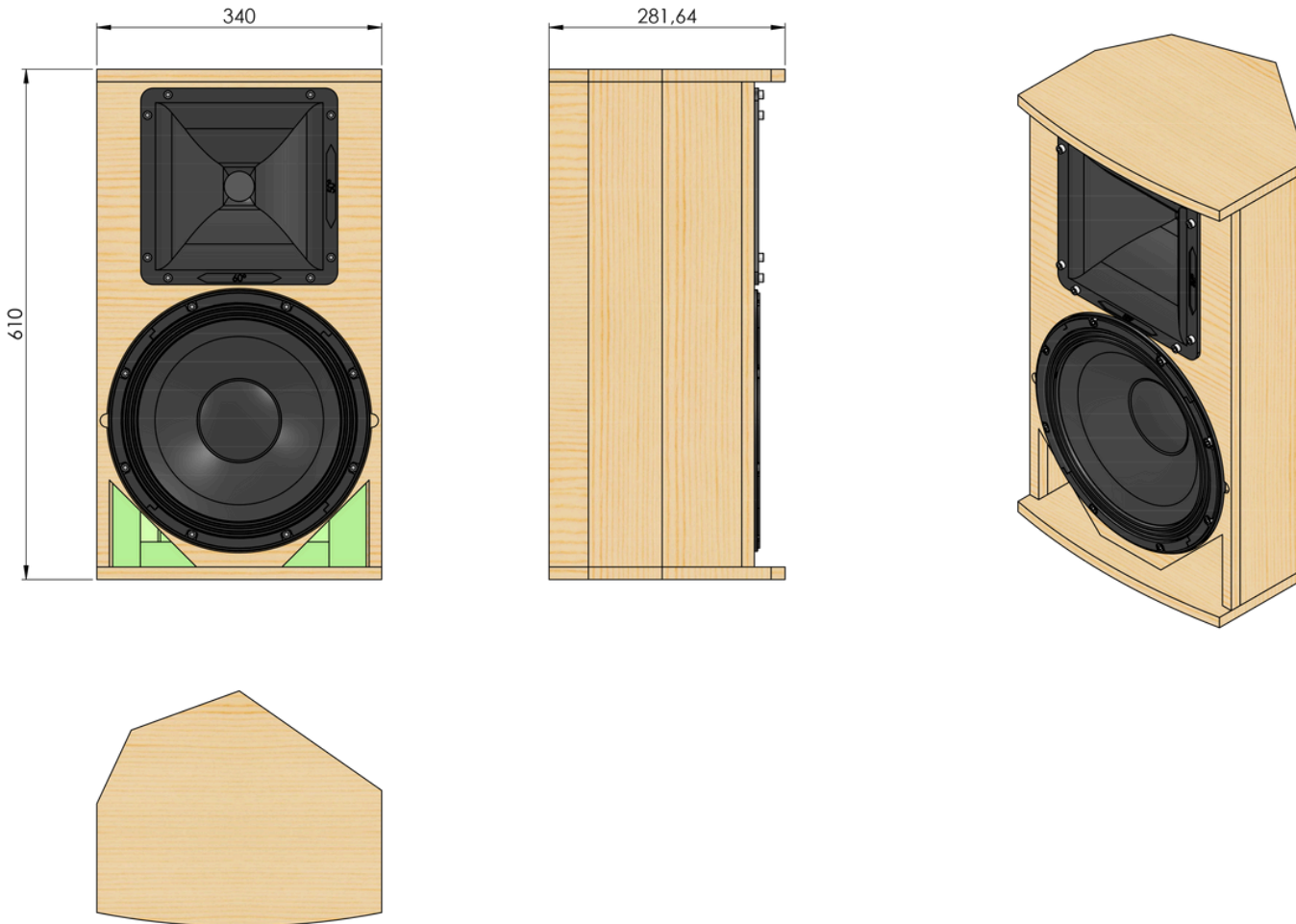



EXPLODED VIEW WITH COMPONENTS

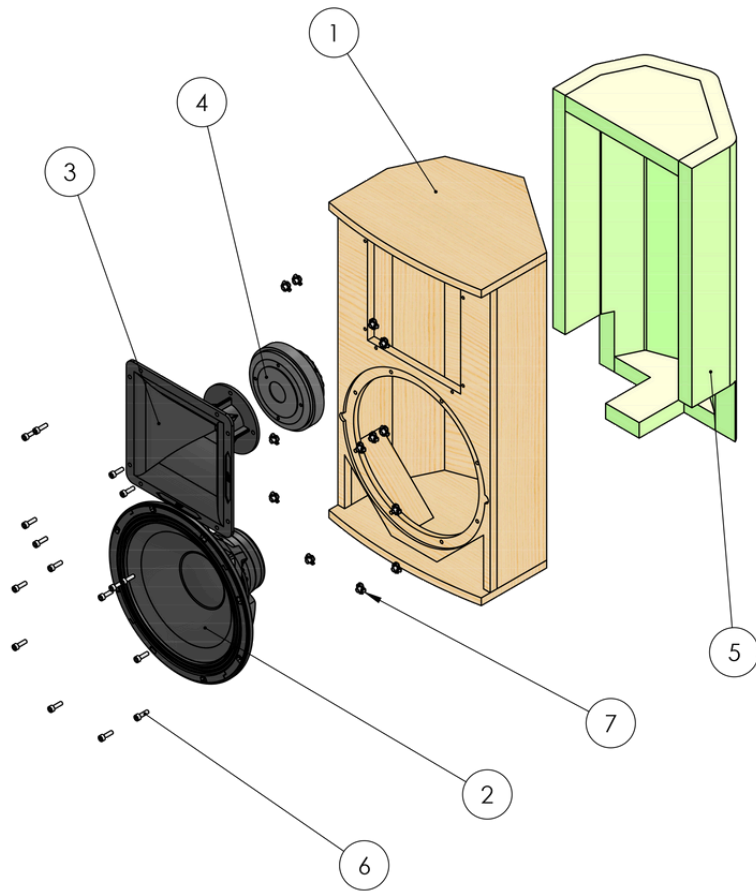

ELEMENT NUMBER	PIECE NUMBER	QUANTITY
1	FR-12MC HI	1
2	12MC700ND-12MCB700	1
3	TD-365	1
4	CD-314Nd/Fe	1
5	FR-12MC HI DAMPING MATERIAL	1
6	SCREW DIN 912 M6x20	16
7	NUT DIN1624 - M6	16



GENERAL VIEW

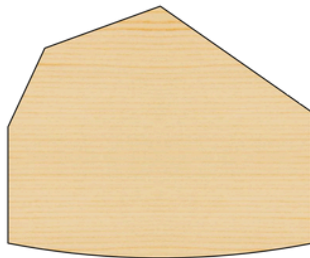
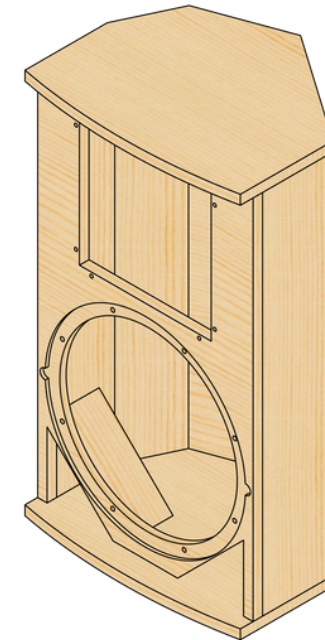
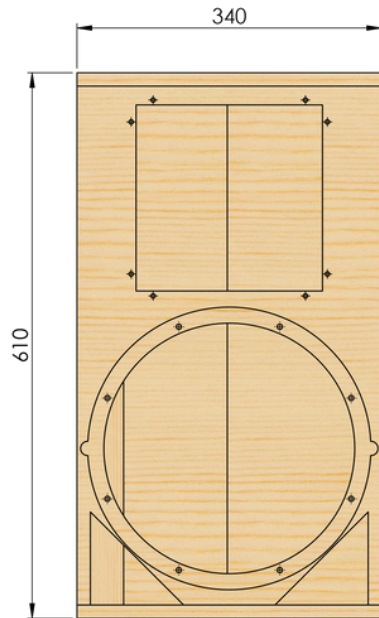



EXPLODED VIEW

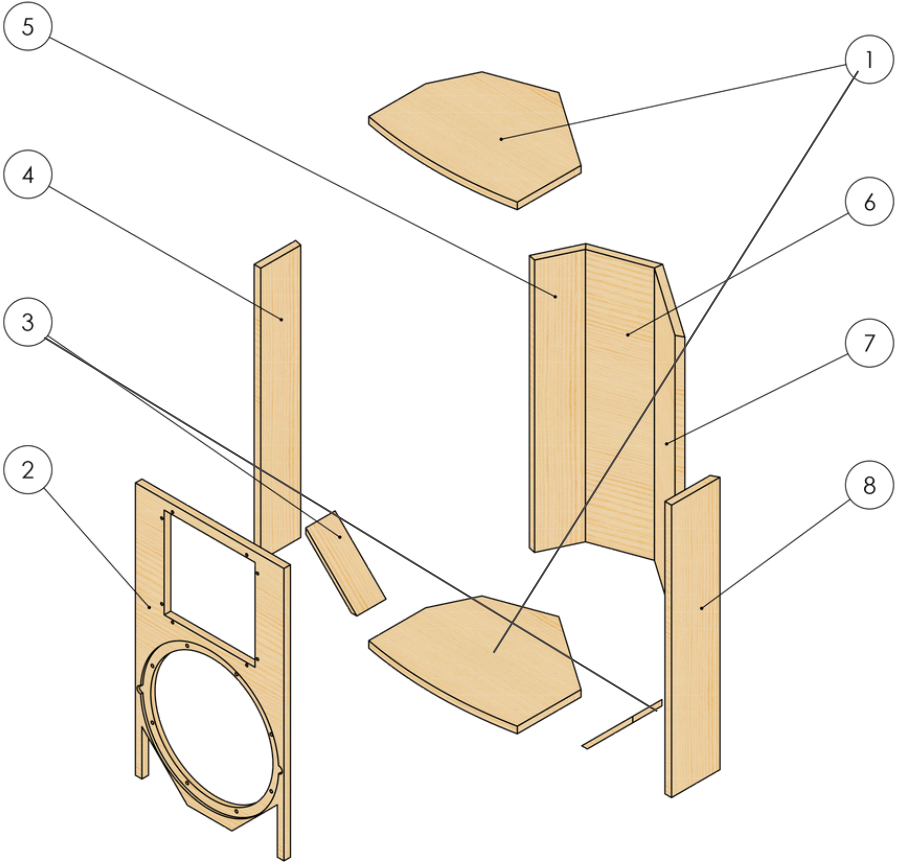
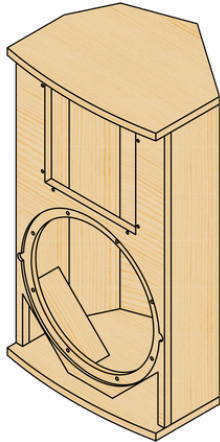

ELEMENT NUMBER	PIECE NUMBER	QUANTITY
1	TOP & BOTTOM PARTS	2
2	FRONT PANEL	1
3	REFLEX	2
4	SIDE_1	1
5	SIDE_2	1
6	SIDE_3	1
7	SIDE_4	1
8	SIDE_5	1



TOP & BOTTOM PARTS

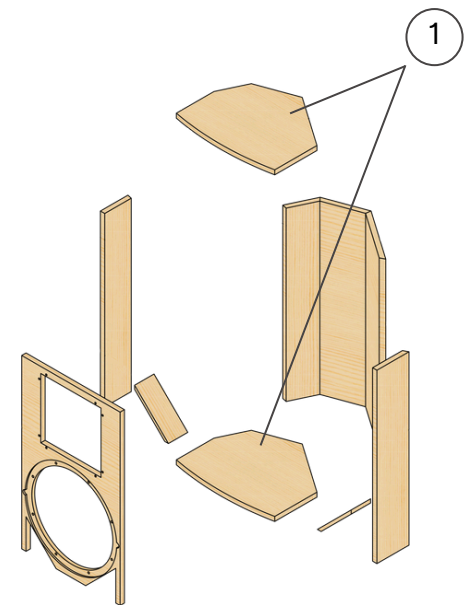
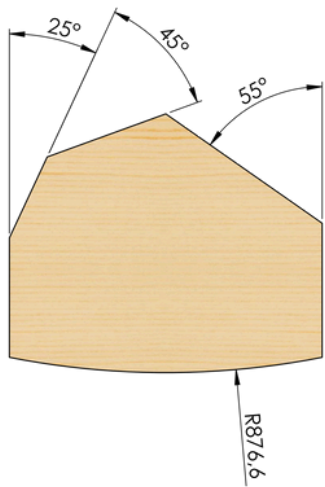
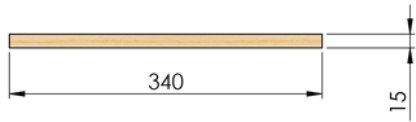
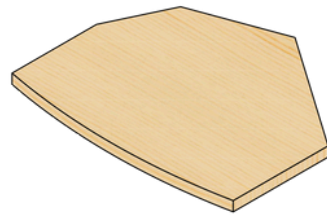
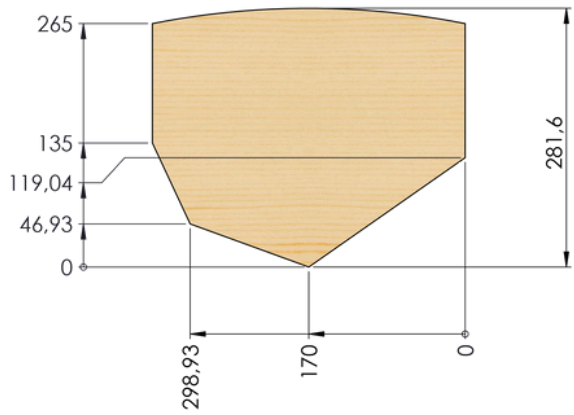



FRONT PANEL

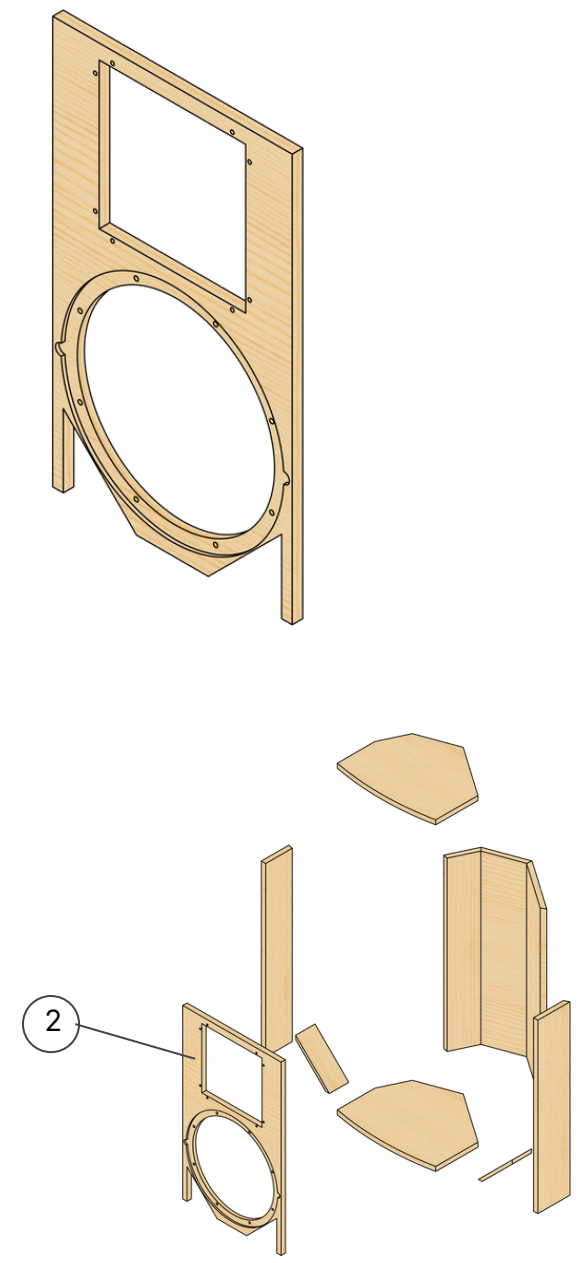
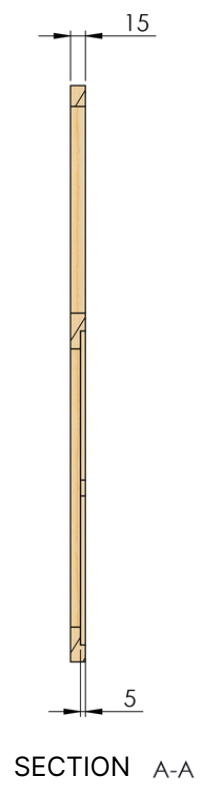
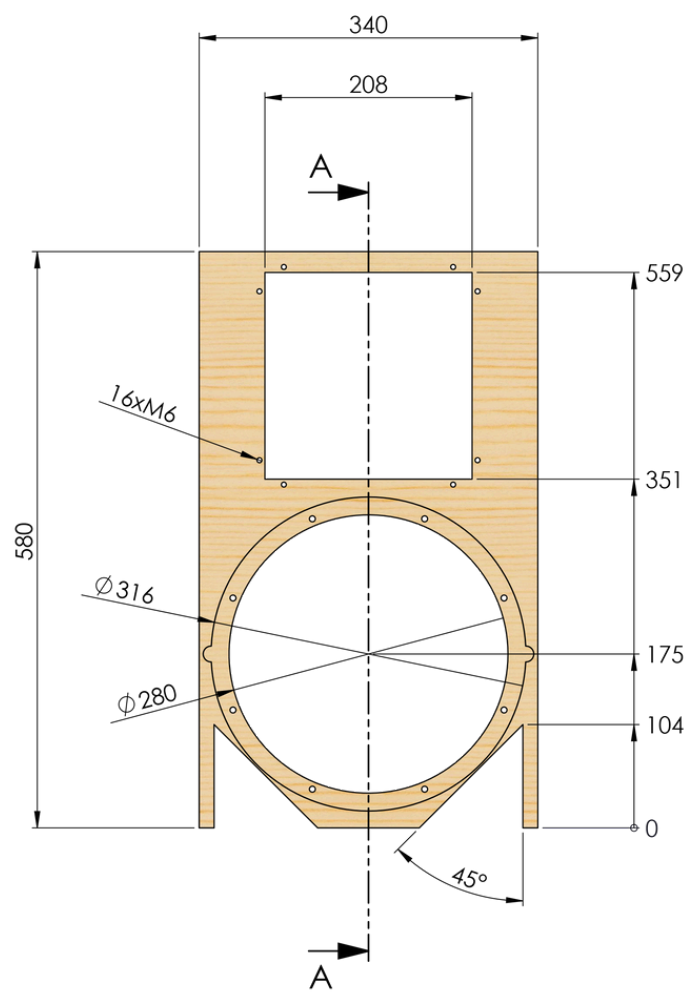



REFLEX

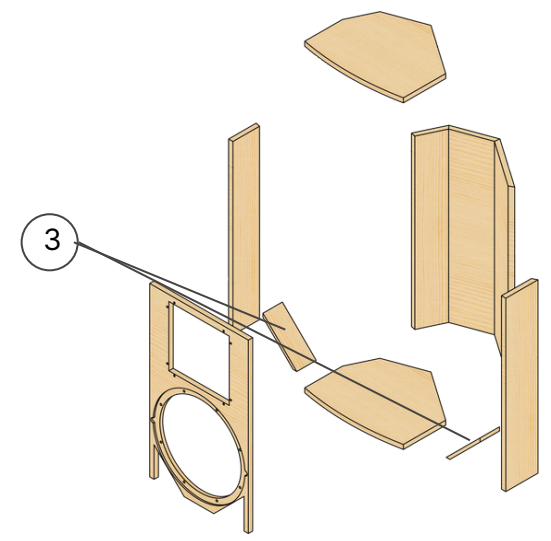
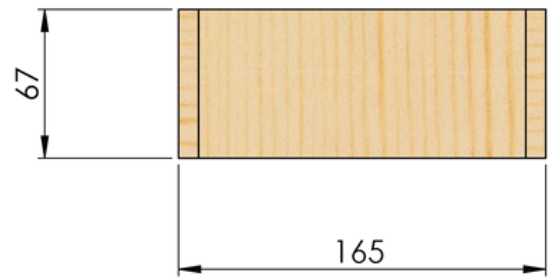
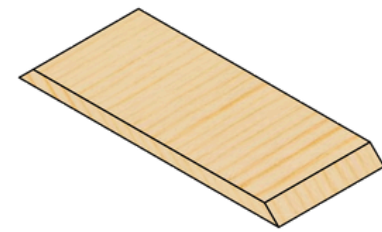
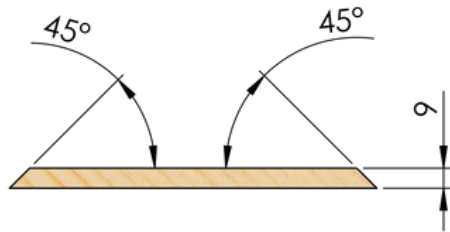



SIDE 1

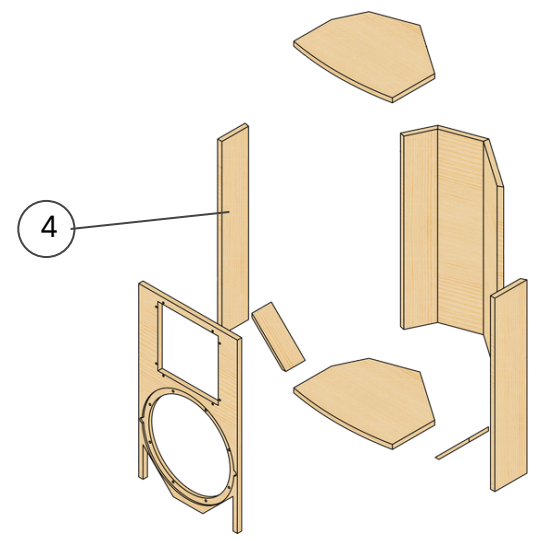
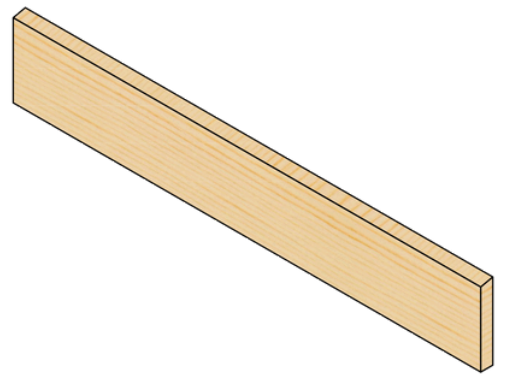
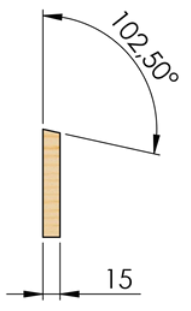



SIDE 2

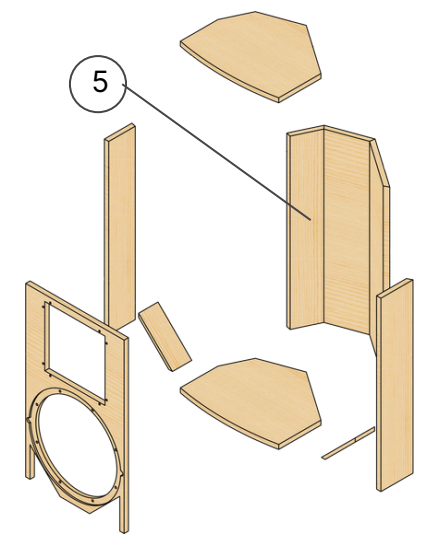
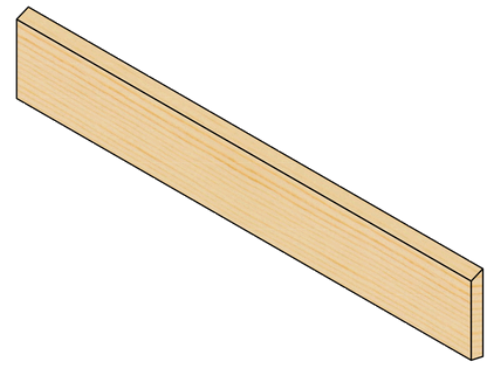
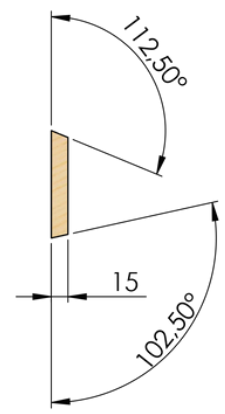
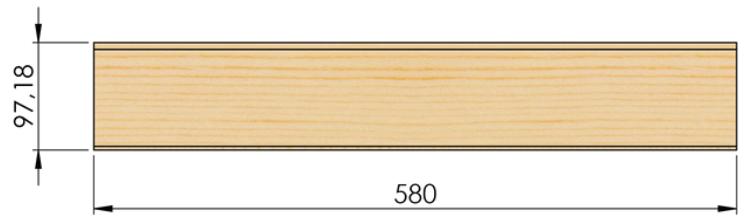



SIDE 3

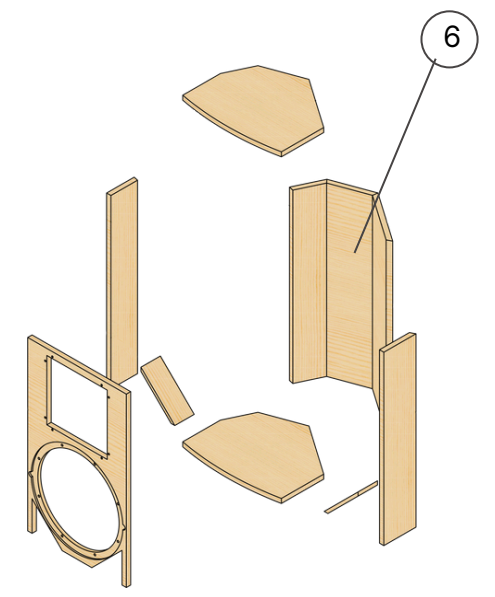
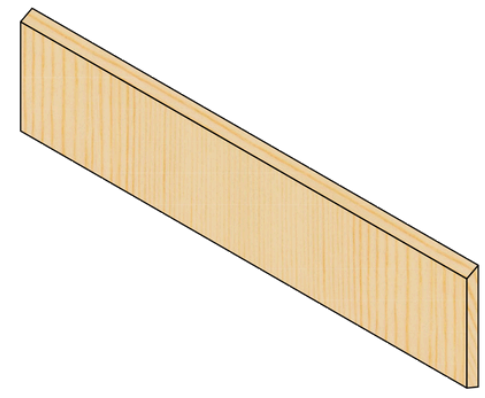
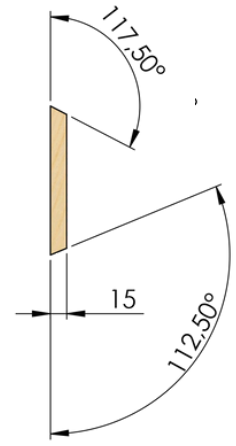



SIDE 4

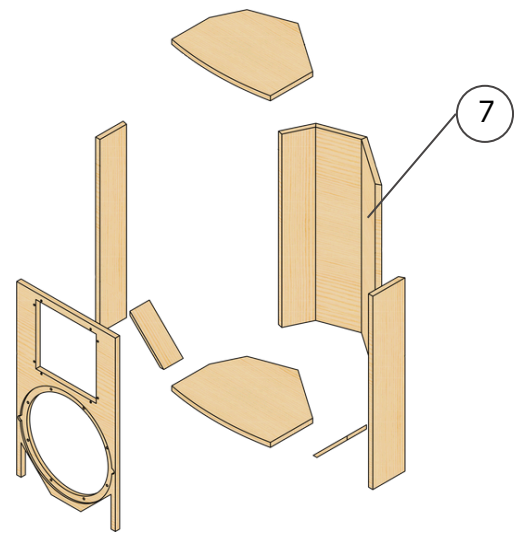
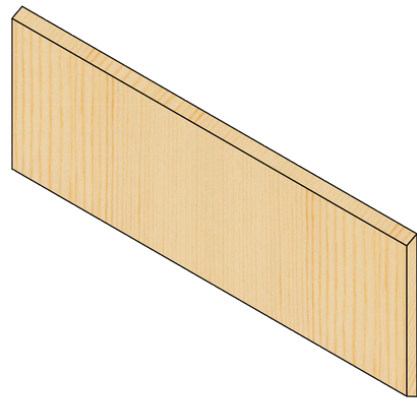
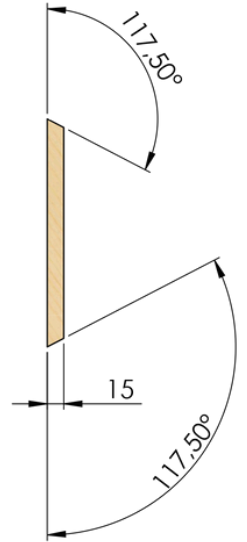



SIDE 5

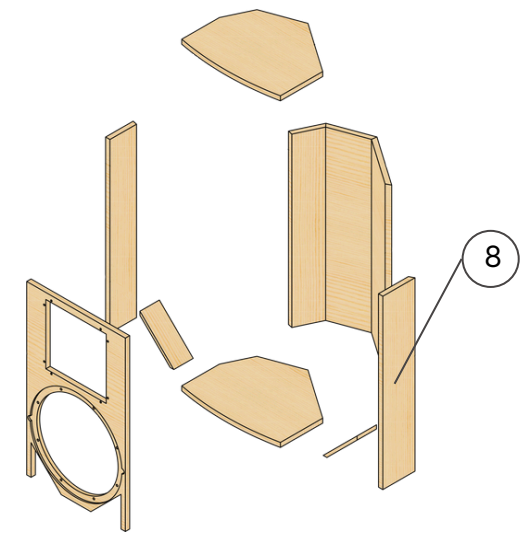
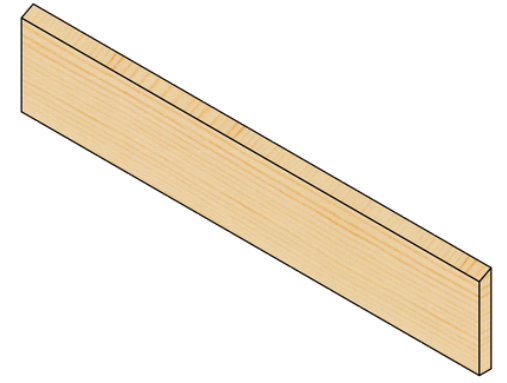
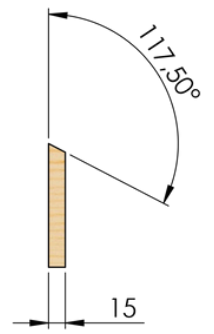

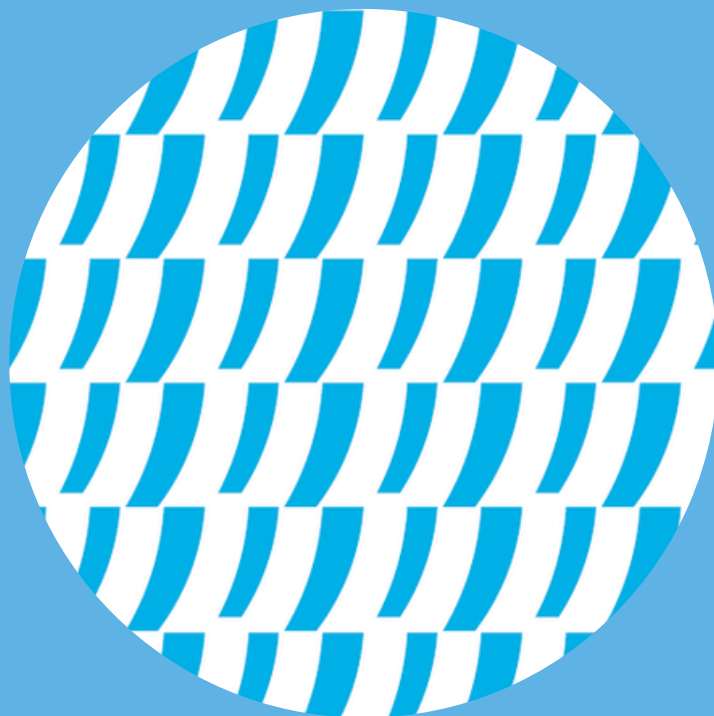

LET'S TALK

www.beyma.com