

FR-14MC HI

FULL RANGE 2 WAY SYSTEM 14"

14MC700ND
CD314Nd/Fe
TD-365



ENCLOSURE RECOMMENDED DESIGN

www.beyma.com



TECHNICAL SPECIFICATIONS

Frequency response (+/-3dB)	75Hz-18KHz
Usable bandwidth (-10dB)	55Hz-19KHz
Maximum SPL(*)	129,5dB
Sensitivity 1W@1m	95dB
HxV Coverage angle (-6dB)	60°x50° rotatable
Transducers LF	14MC700ND
Transducers HF	CD314Nd-Fe/Ti
AES Power Handling	700
Nominal impedance	8Ω
Connectors	2xNL4
Box dimmensions (**)	400 x 670 x 332.2 (Birch Plywood 15/9mm)

(*) Peak level at 1m under free field conditions usin pink noise with 6dB crest factor

(**) All dimmensions in millimeters

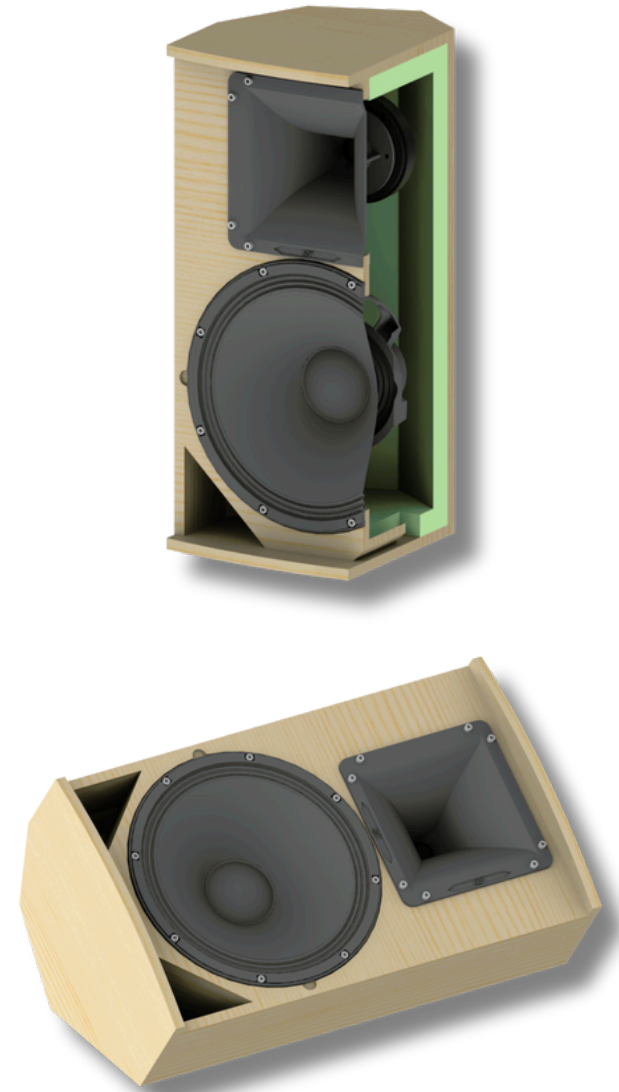



PRESSETS

FR-14MC HI	f(Hz)	Q	Gain(dB)
L-SH 12dB/oct	200	-	3,5
-	360	2	-6,8
-	1400	2,3	-2,5
-	4000	1.5	-3
LIMITER	Thres (dBu)	Attack (ms)	Release (ms)
PEAK	10,7	8	128

* for 32dB gain amplifier
* frequency response graph CD314Nd/Ti with TD365 horn

PASSIVE CROSSOVER DESIGN

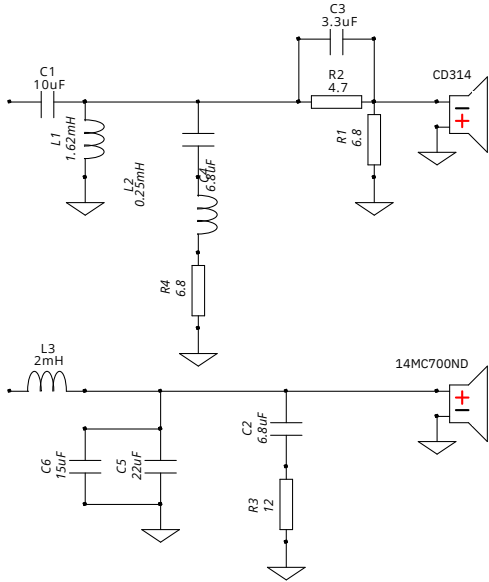

FREQUENCY RESPONSE

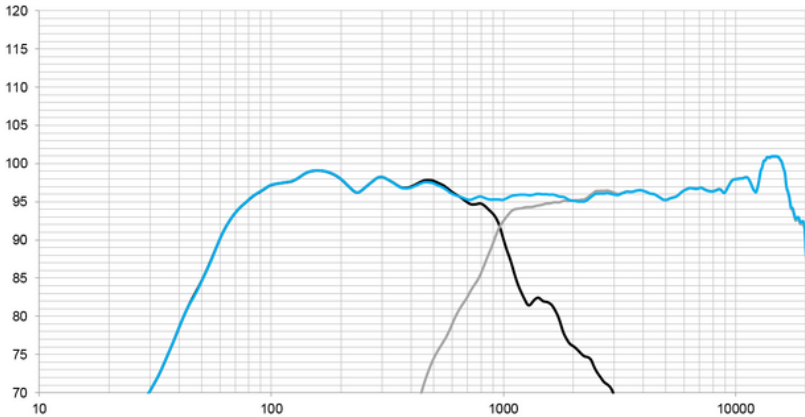

IMPEDANCE

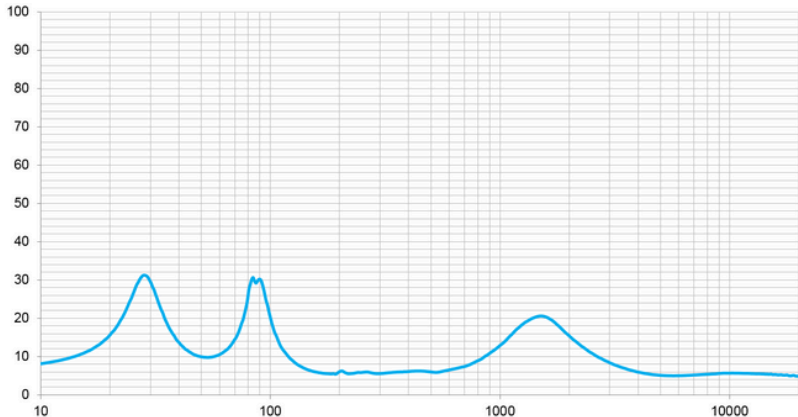



GENERAL VIEW WITH COMPONENTS

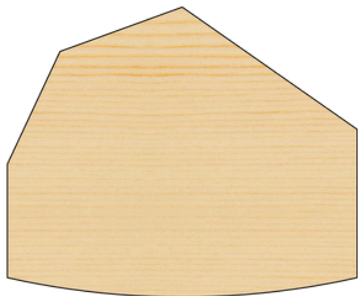
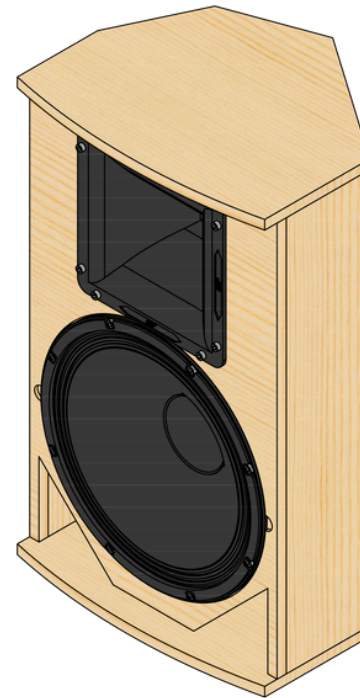
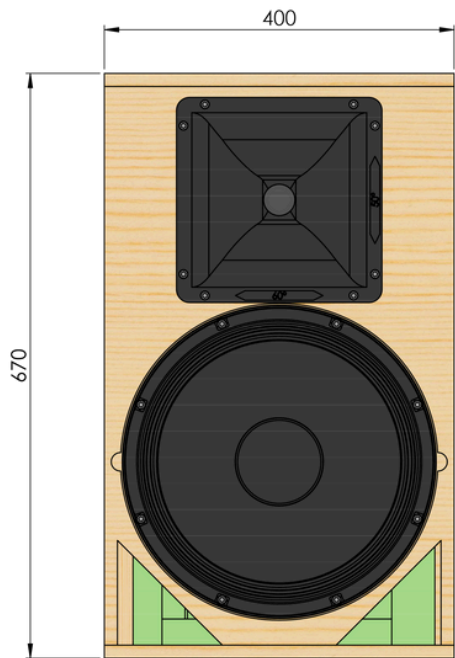



EXPLODED VIEW WITH COMPONENTS

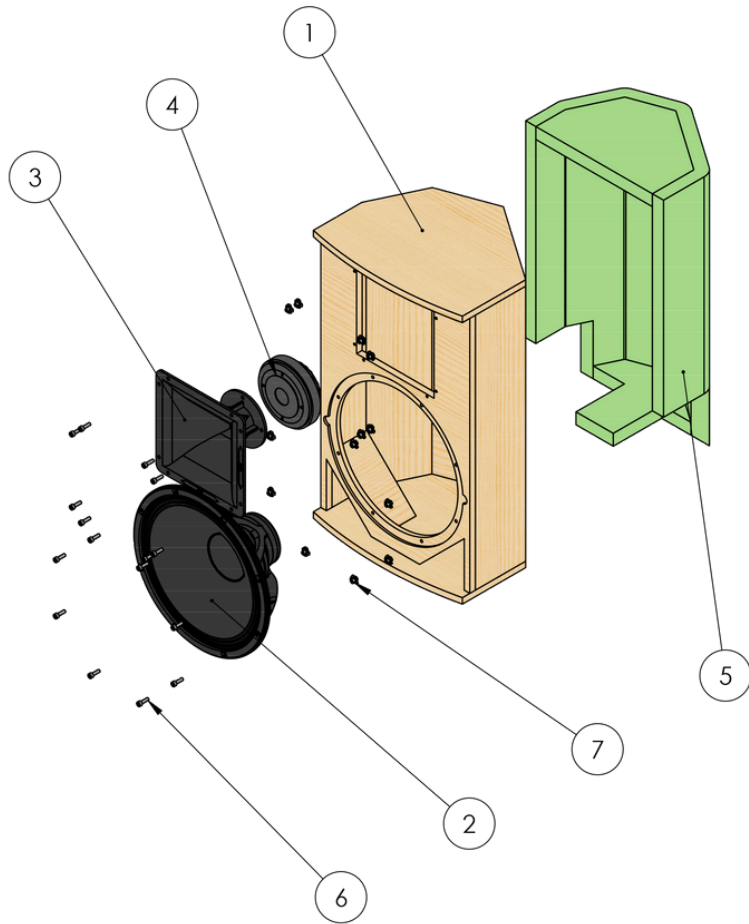

ELEMENT NUMBER	PIECE NUMBER	QUANTITY
1	FR-14MC HI	1
2	14MC700ND	1
3	TD-365	1
4	CD-314Nd/Fe	1
5	FR-14MC HI DAMPING MATERIAL	1
6	SCREW DIN 912 M6x20	16
7	NUT DIN1624 - M6	16



GENERAL VIEW

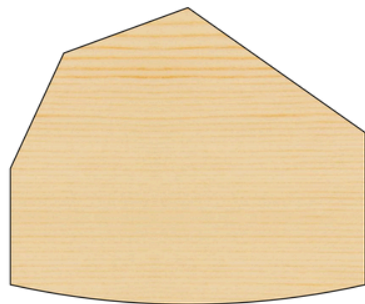
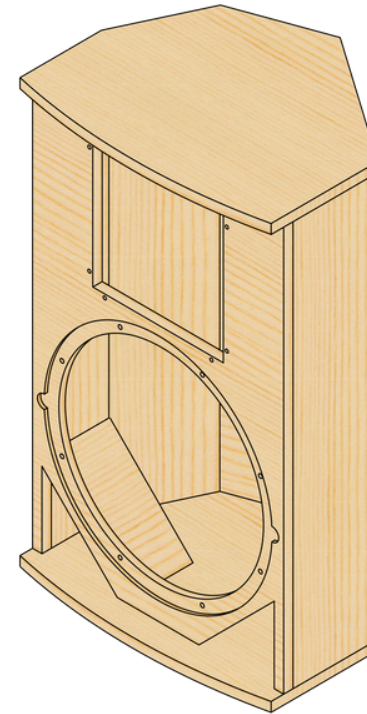
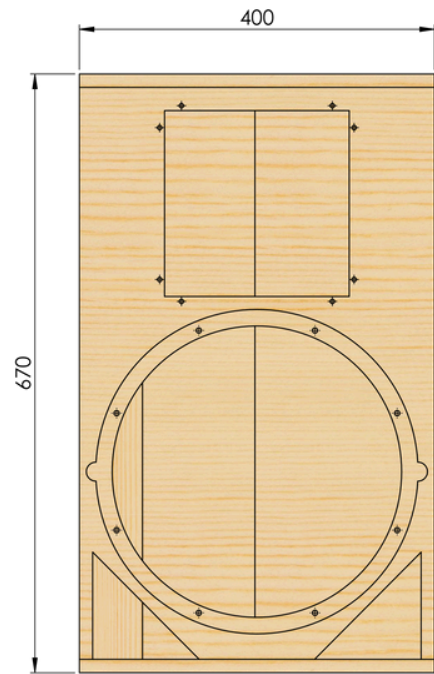



EXPLODED VIEW

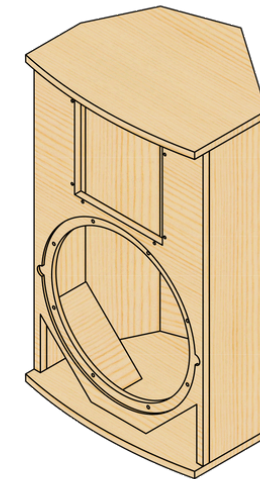
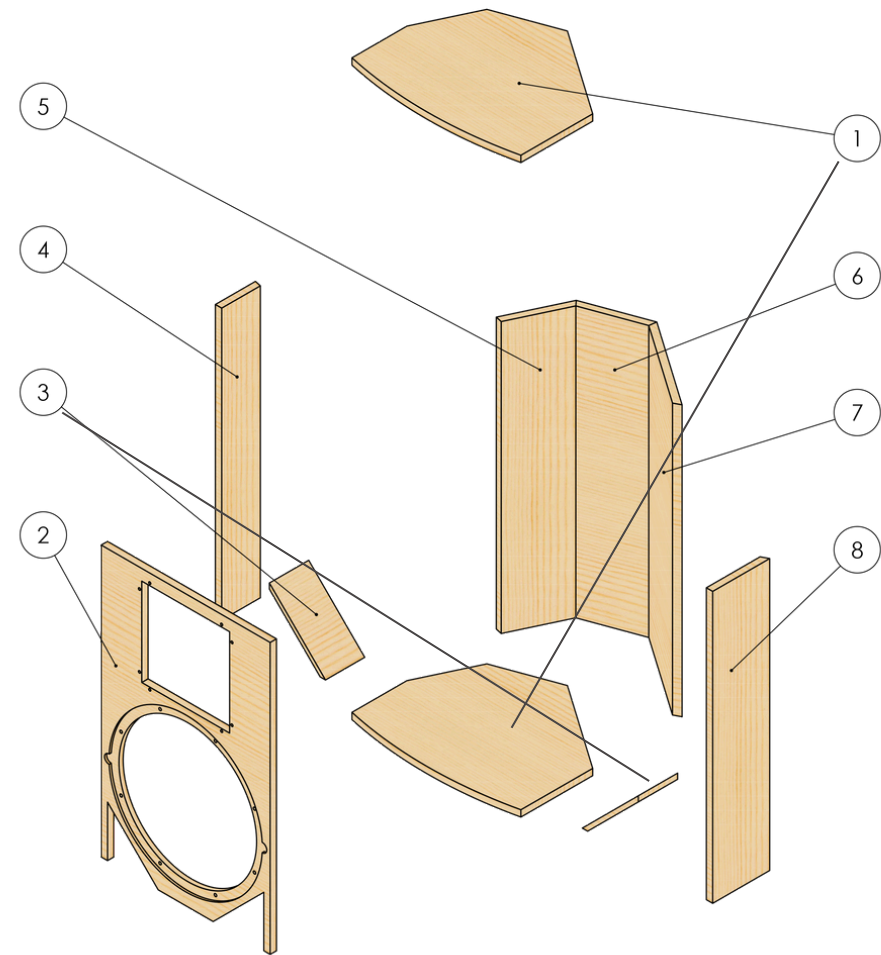

ELEMENT NUMBER	PIECE NUMBER	QUANTITY
1	TOP & BOTTOM PARTS	2
2	FRONT PANEL	1
3	REFLEX	2
4	SIDE_1	1
5	SIDE_2	1
6	SIDE_3	1
7	SIDE_4	1
8	SIDE_5	1



TOP & BOTTOM PARTS

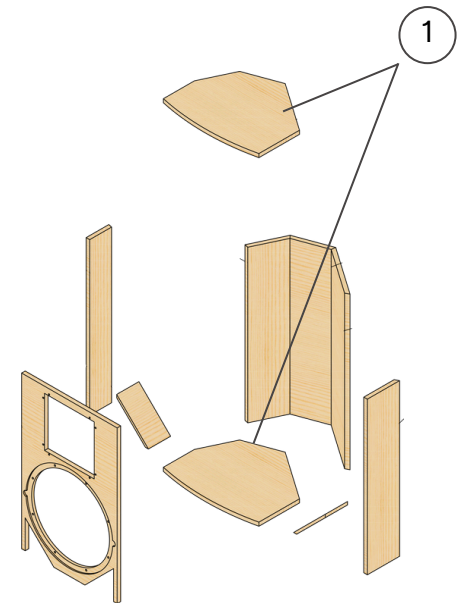
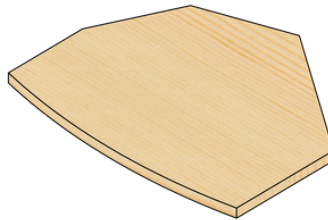
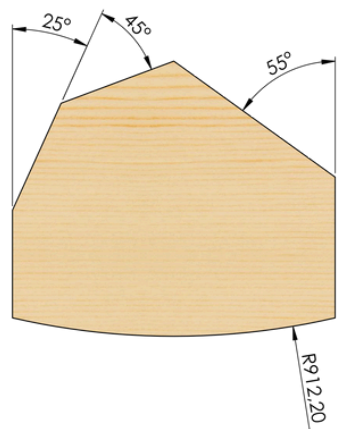
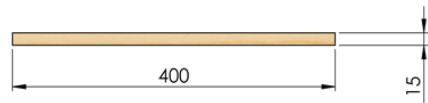
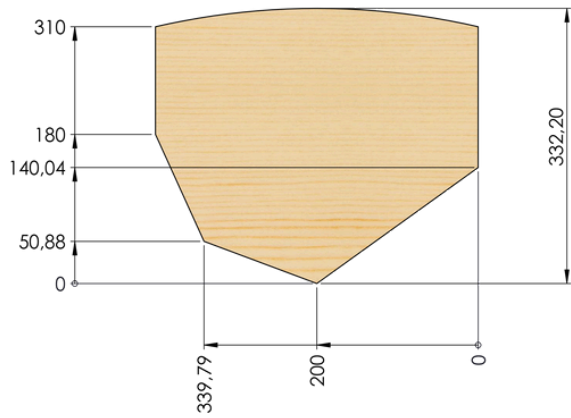



REFLEX

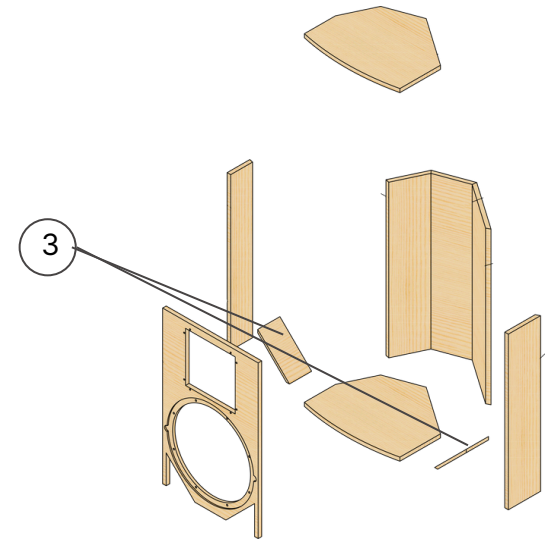
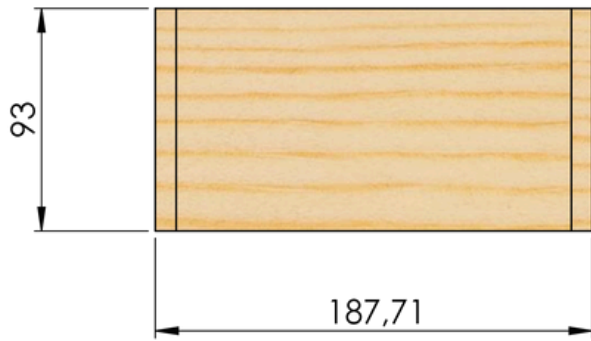
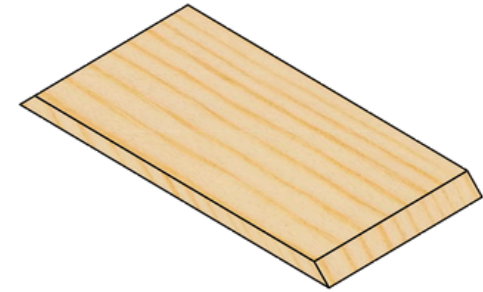
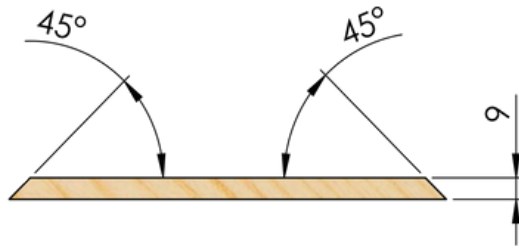



SIDE 1

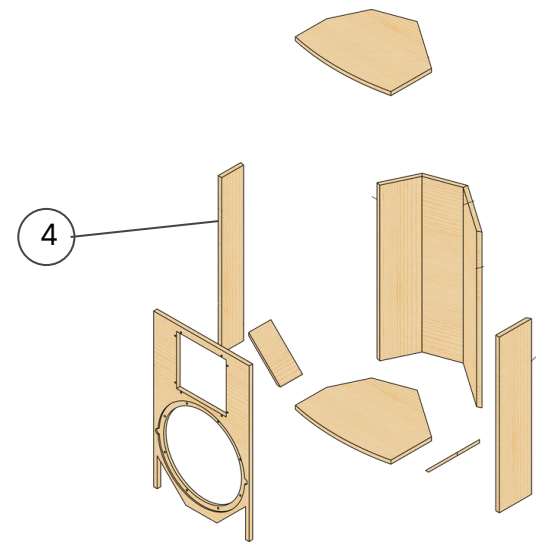
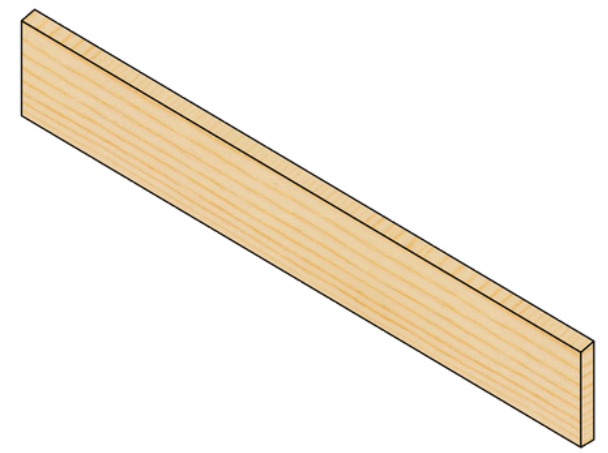
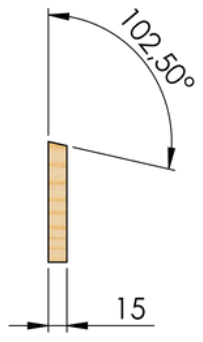



SIDE 2

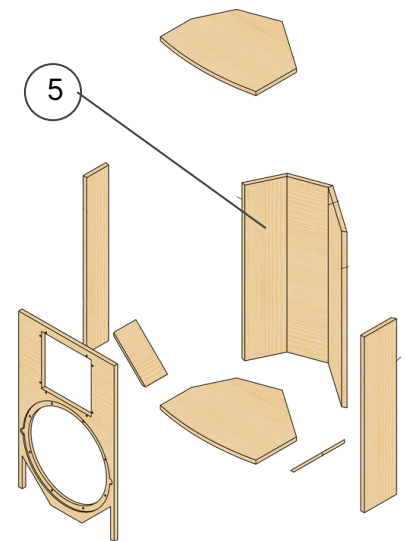
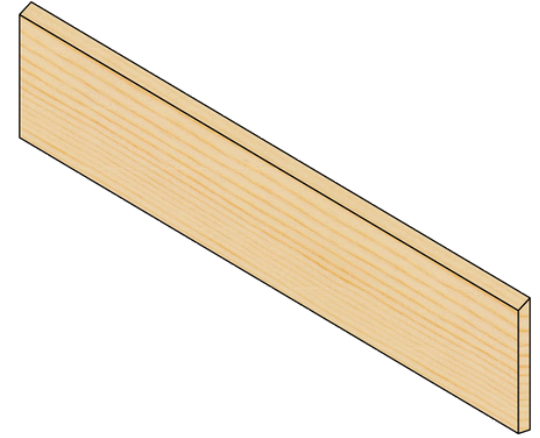
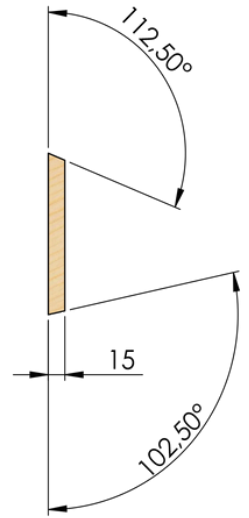



SIDE 3

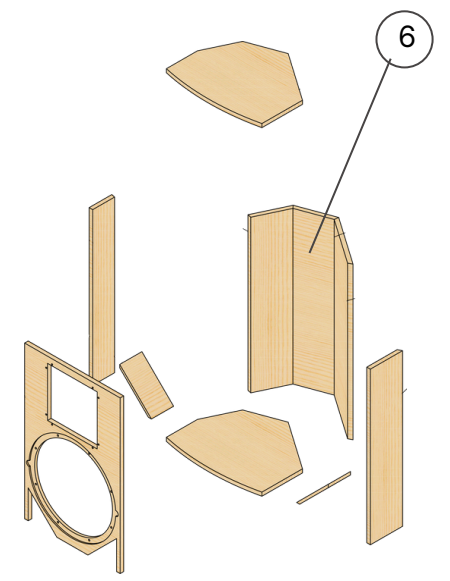
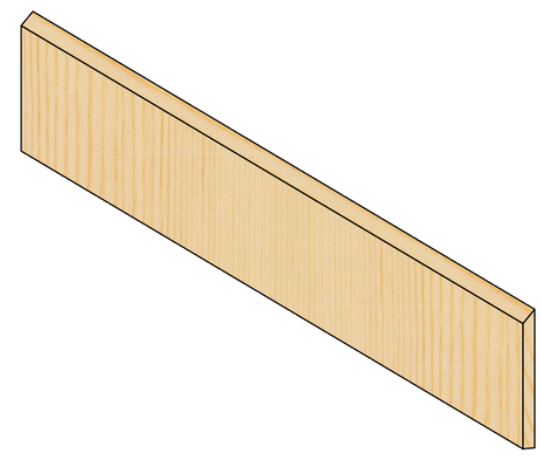
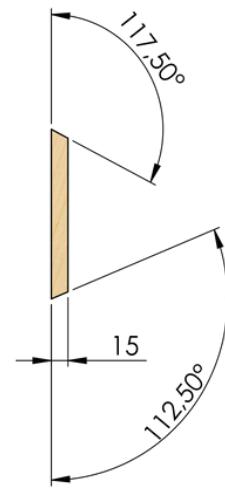
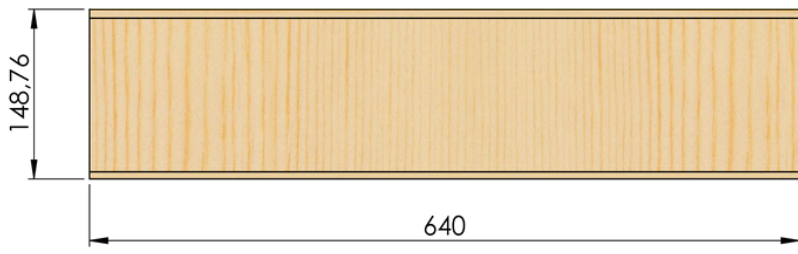



SIDE 4

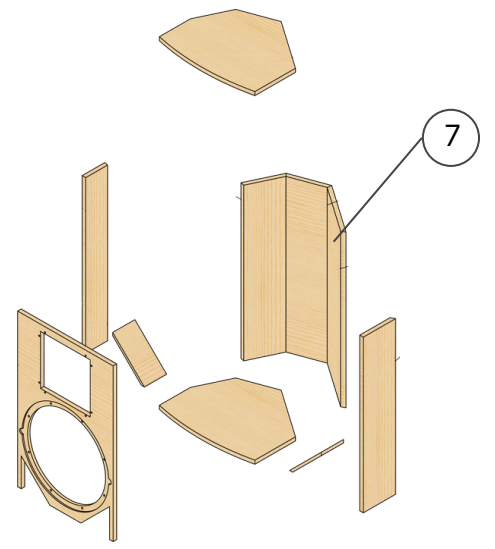
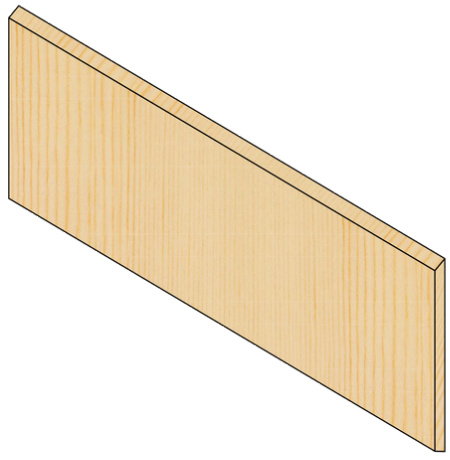
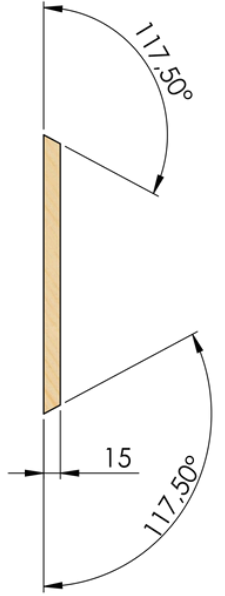
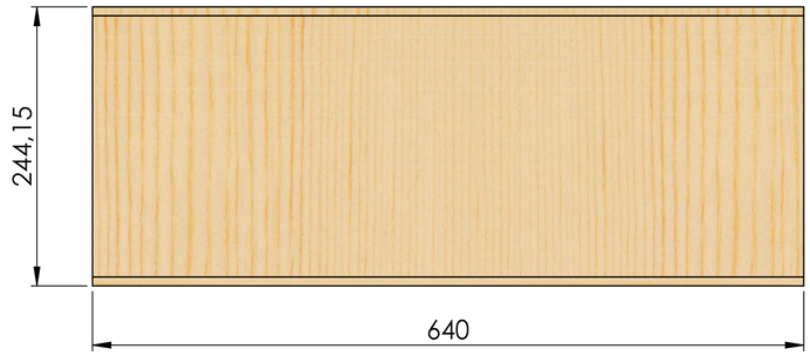



SIDE 5

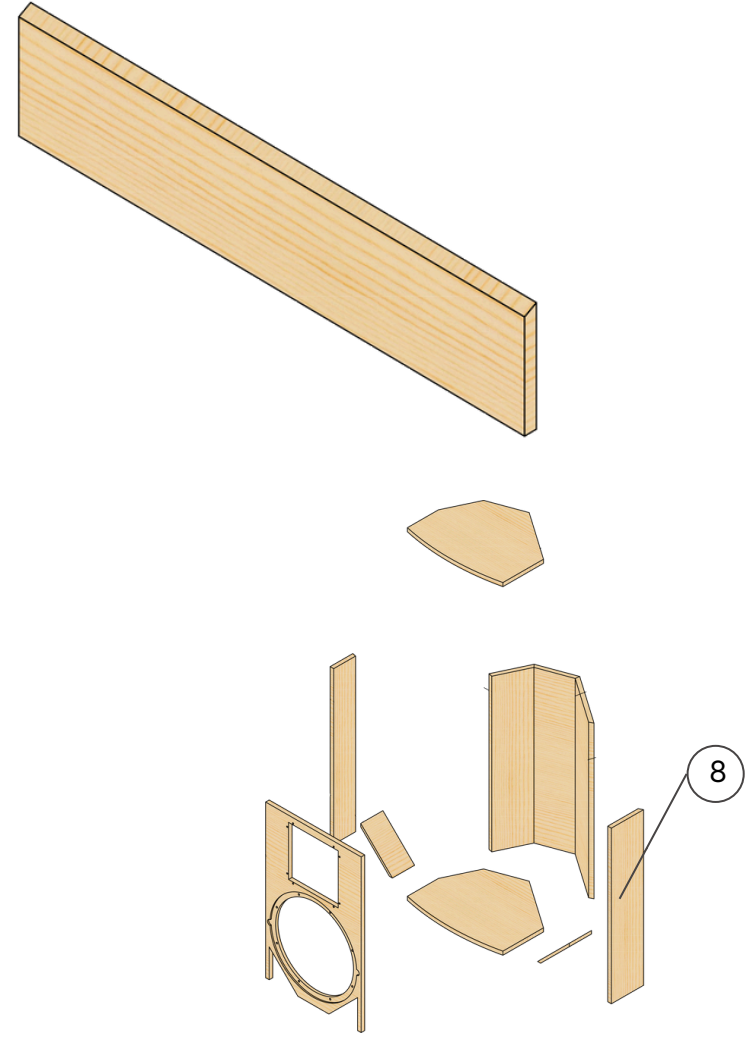
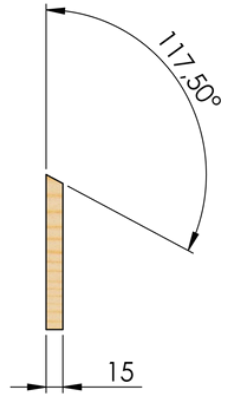

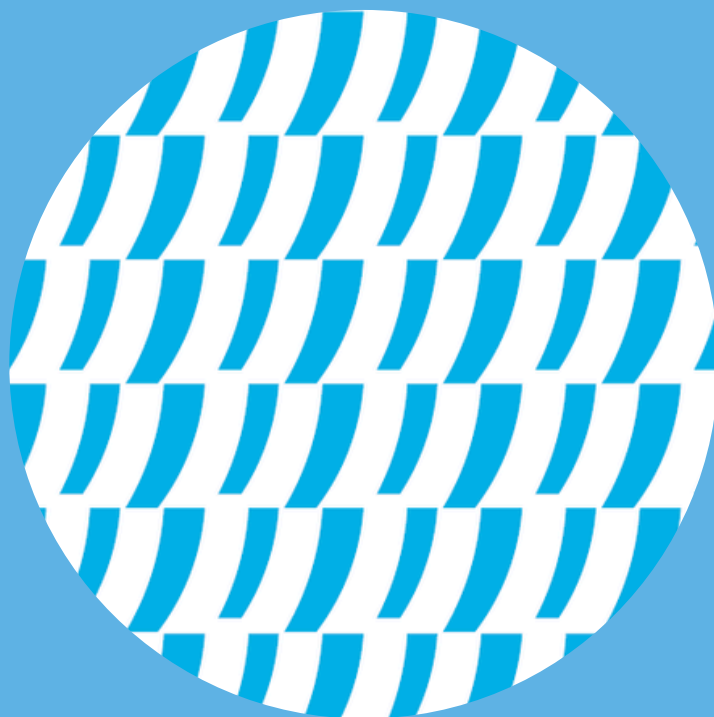

LET'S TALK

www.beyma.com