

# FR-15MC

FULL RANGE 2 WAY SYSTEM 15"

15MC500 / 15MCS500

CD2514Nd/Fe

TD-365



ENCLOSURE RECOMMENDED DESIGN

[www.beyma.com](http://www.beyma.com)



# TECHNICAL SPECIFICATIONS

Frequency response (+/-3dB)	65Hz-18KHz
Usable bandwidth (-10dB)	55Hz-19KHz
Maximum SPL(*)	129dB
Sensitivity 1W@1m	96dB
HxV Coverage angle (-6dB)	60°x50° rotatable
Transducers LF	15MC500/15MCS500
Transducers HF	CD2514Nd/Fe
AES Power Handling	500
Nominal impedance	8Ω
Connectors	2xNL4
Box dimensions (**)	430 x 700 x 419.76 (Birch Plywood 15/9mm)

(\*) Peak level at 1m under free field conditions usin pink noise with 6dB crest factor

(\*\*) All dimmensions in millimeters





# PRESSETS

FR-15MC	f(Hz)	Q	Gain(dB)
L-SH 12dB/oct	160	-	3
-	240	5	5
-	270	7	-5
-	530	6	4
LIMITER	Thres (dBu)	Attack (ms)	Release (ms)
PEAK	9,2	8	128

\* for 32dB gain amplifier  
\* frequency response graph CD2514Nd/Ti with TD365 horn

# PASSIVE CROSSOVER DESIGN

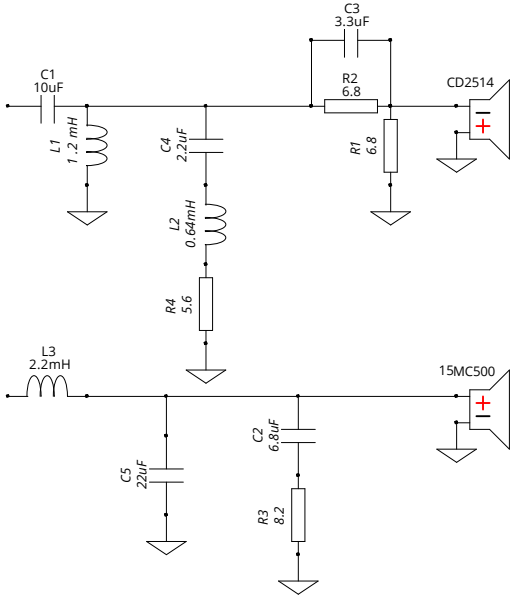

# FREQUENCY RESPONSE

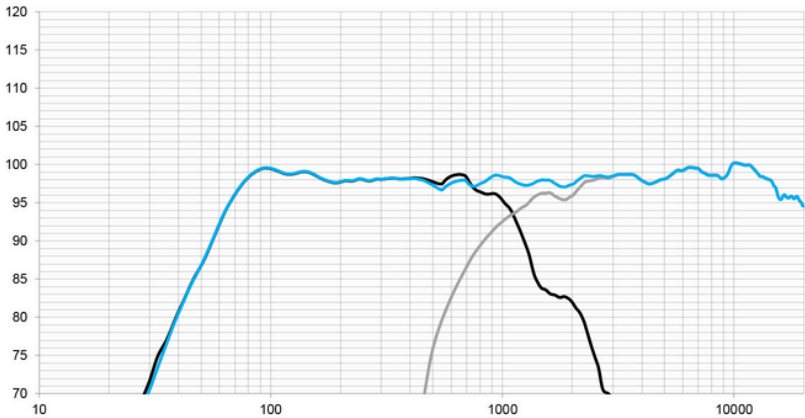

# IMPEDANCE

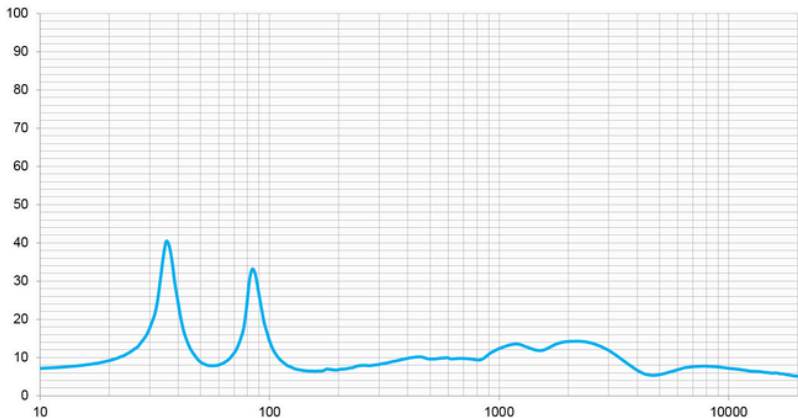



# GENERAL VIEW WITH COMPONENTS

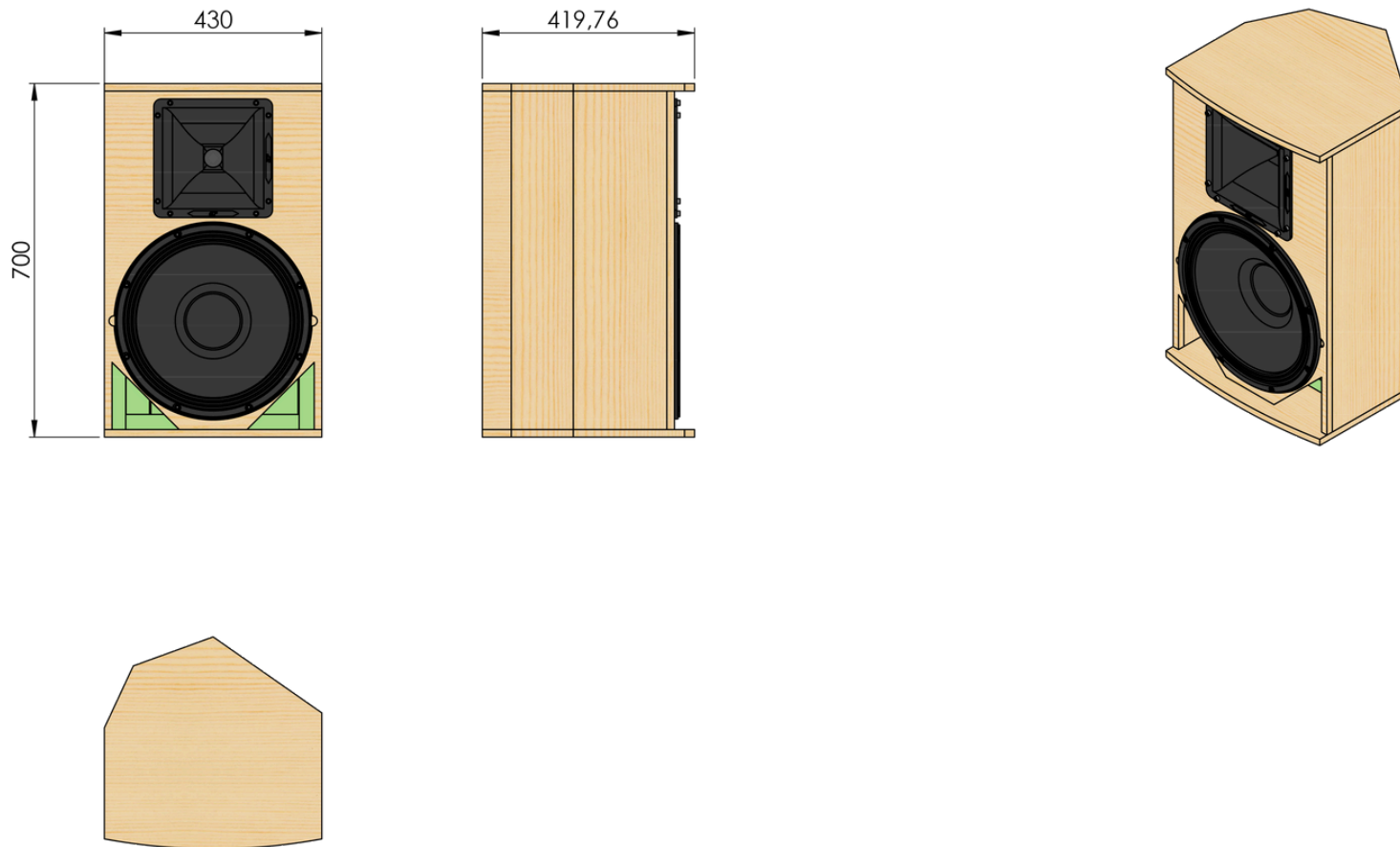



# EXPLODED VIEW WITH COMPONENTS

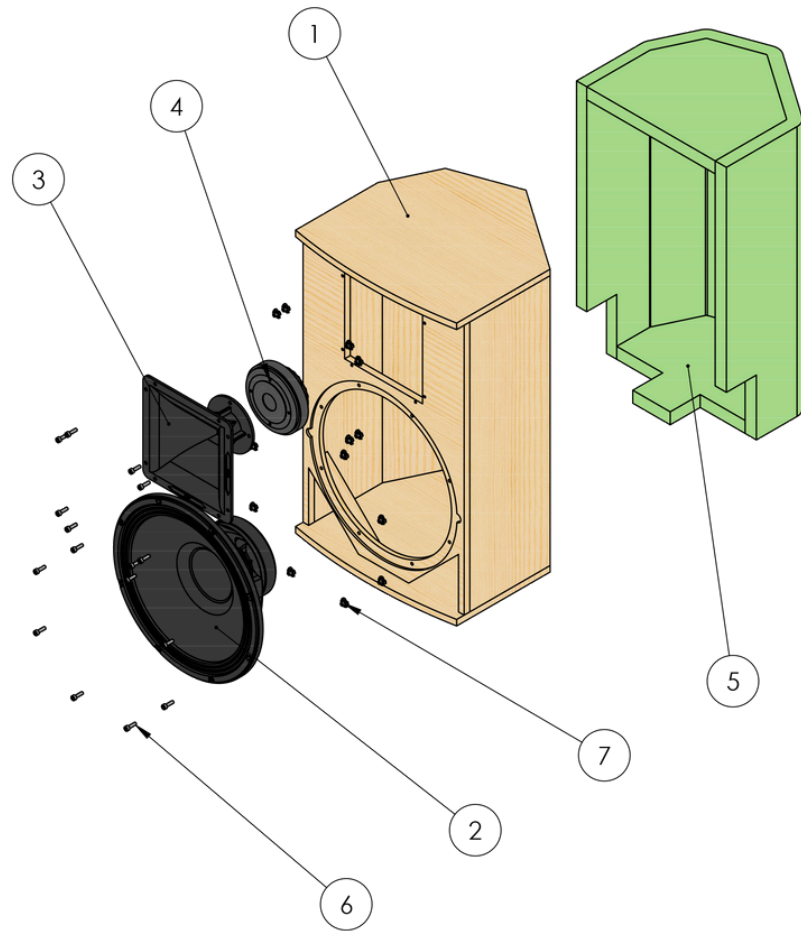

ELEMENT NUMBER	PIECE NUMBER	QUANTITY
1	FR-15MC	1
2	15MC500 / 15MCS500	1
3	TD365	1
4	CD2514Nd/Fe	1
5	DAMPING MATERIAL	1
6	SCREW DIN 912 M6x20	16
7	NUT DIN1624 - M6	16



# GENERAL VIEW

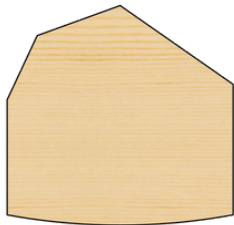
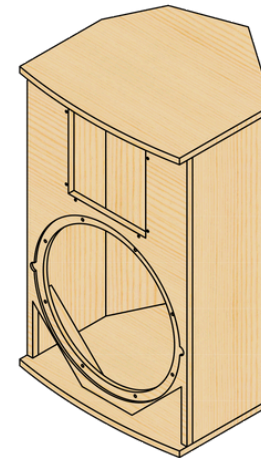
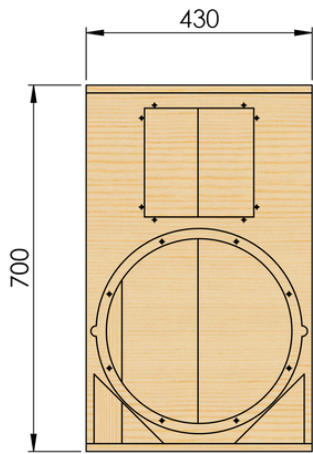



# EXPLODED VIEW

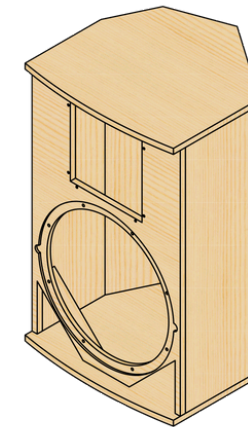
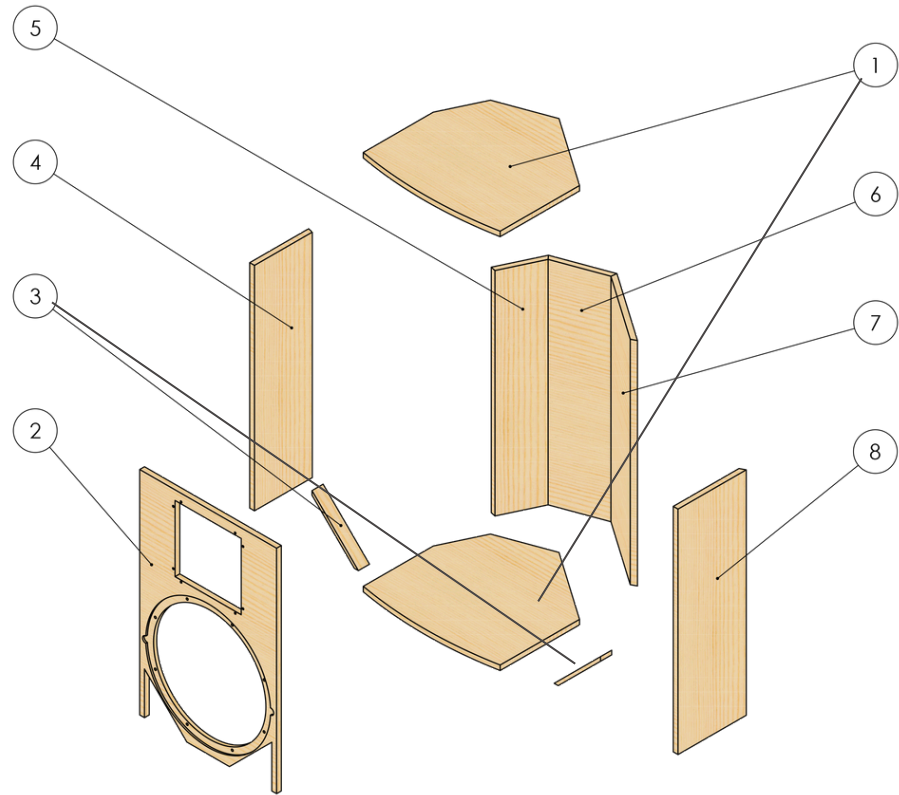

ELEMENT NUMBER	PIECE NUMBER	QUANTITY
1	TOP & BOTTOM PARTS	2
2	FRONT PANEL	1
3	REFLEX	2
4	SIDE_1	1
5	SIDE_2	1
6	SIDE_3	1
7	SIDE_4	1
8	SIDE_5	1



# TOP & BOTTOM PARTS

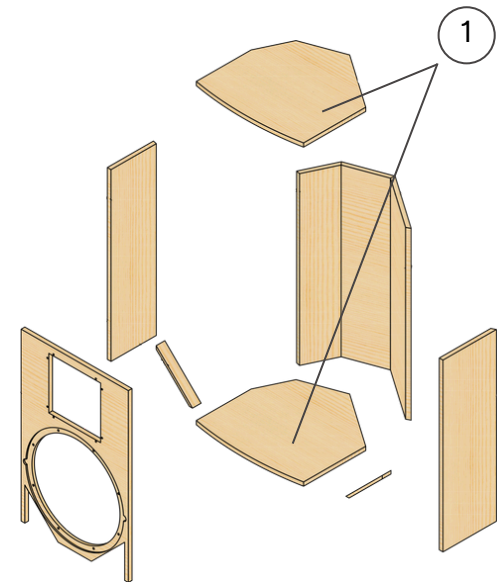
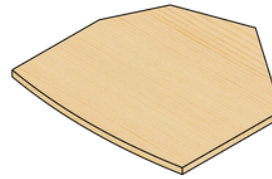
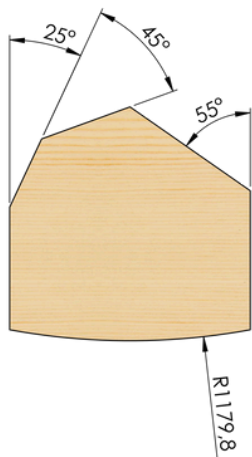
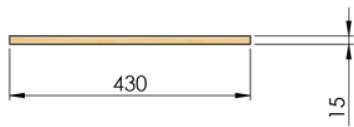
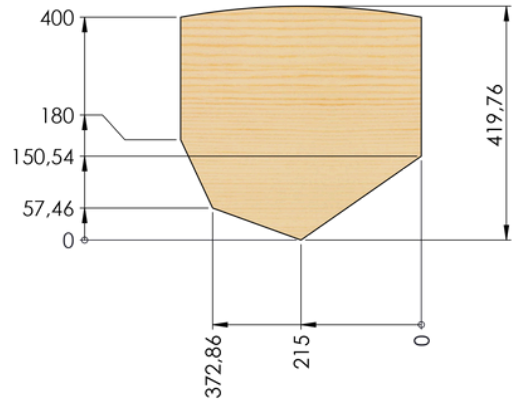





# FRONT PANEL

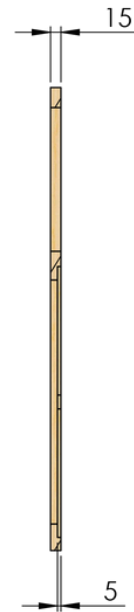
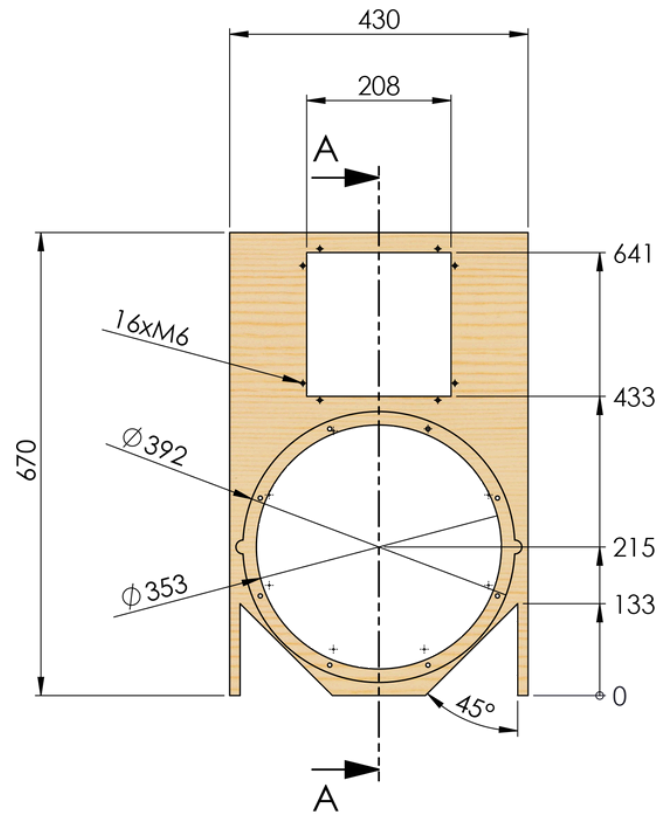

SECTION A-A

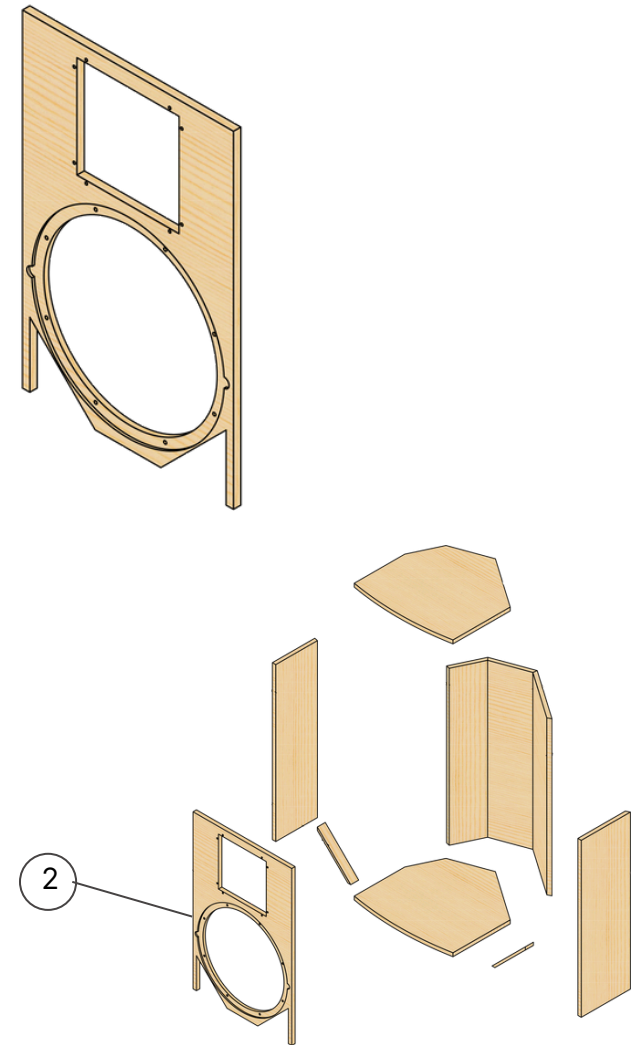



# REFLEX

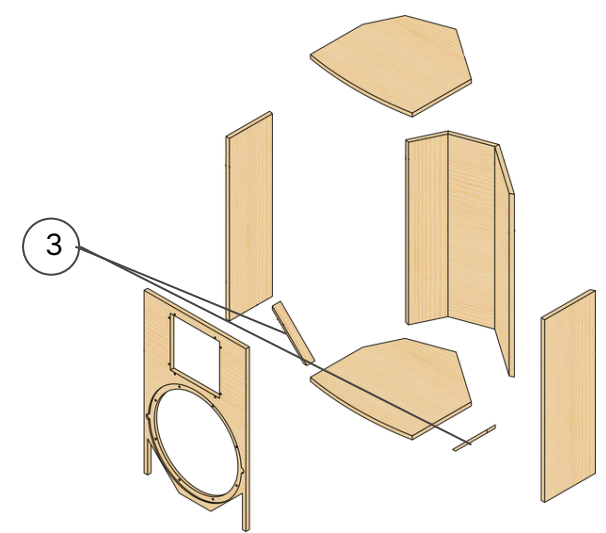
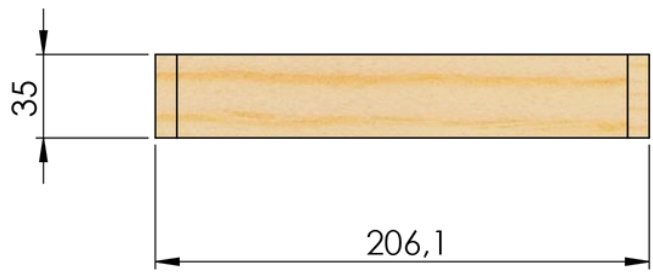
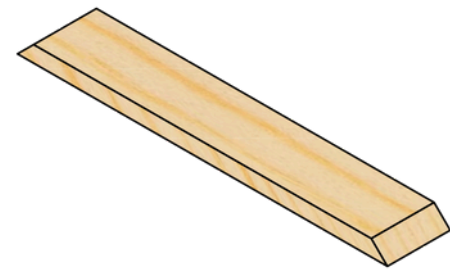
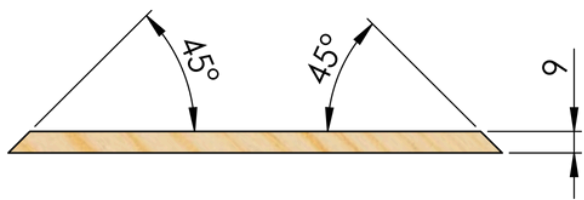



SIDE 1

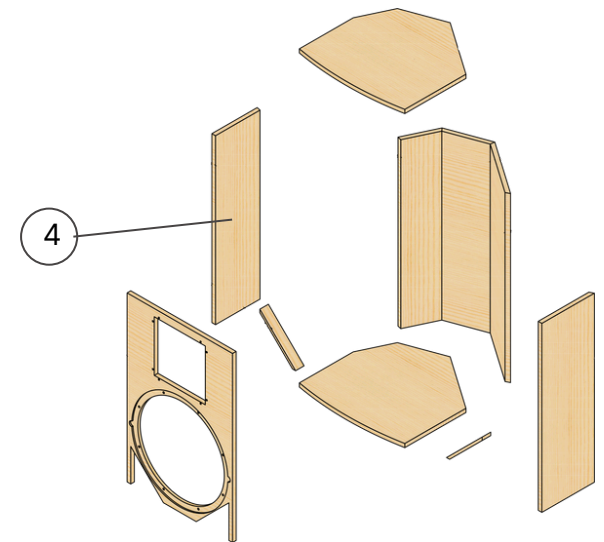
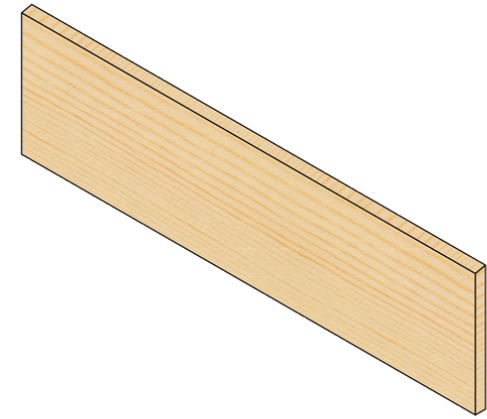
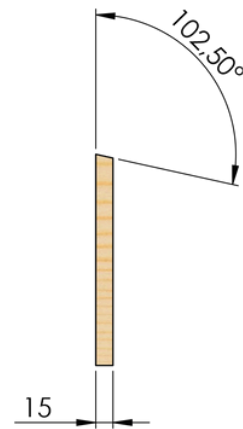
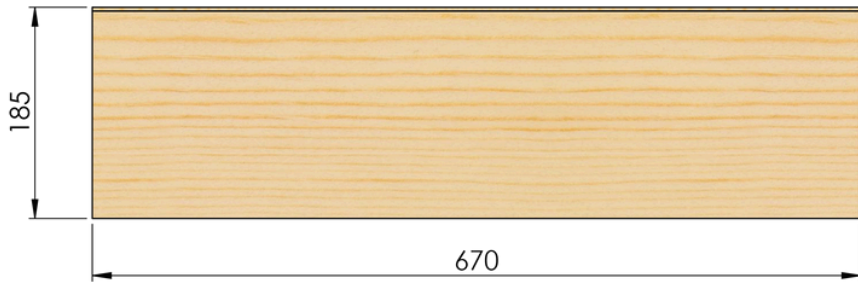



SIDE 2

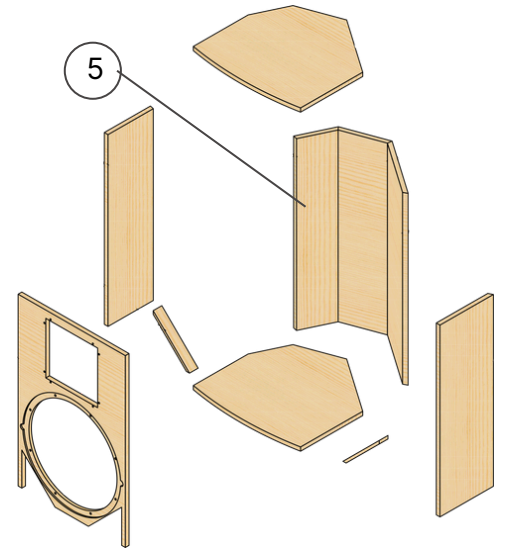
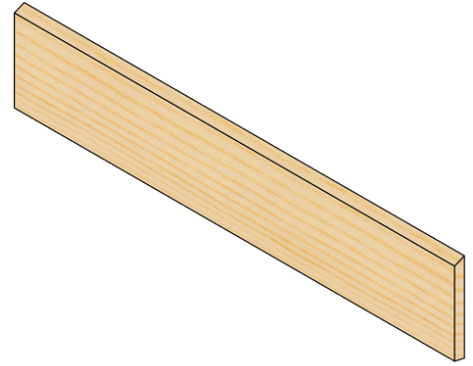
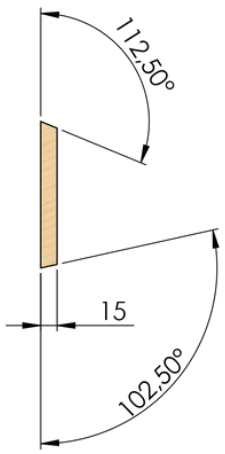



SIDE 3

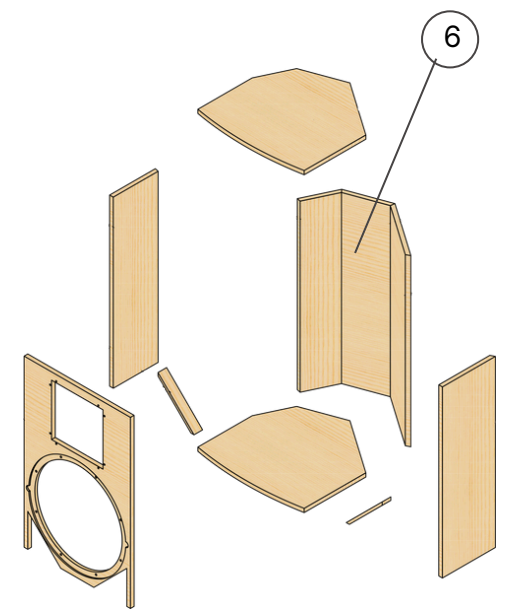
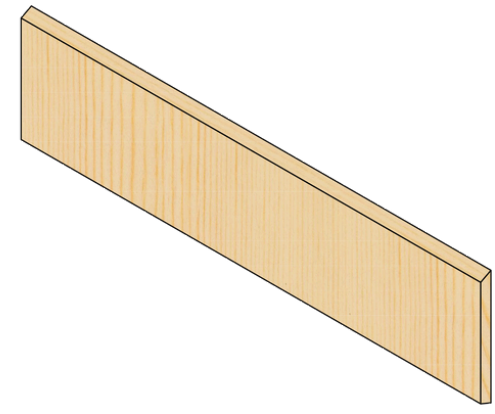
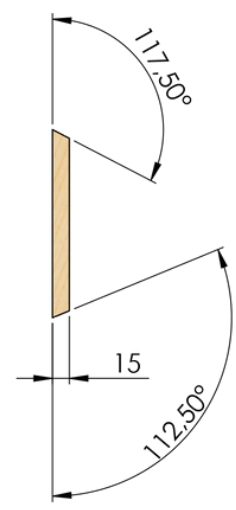
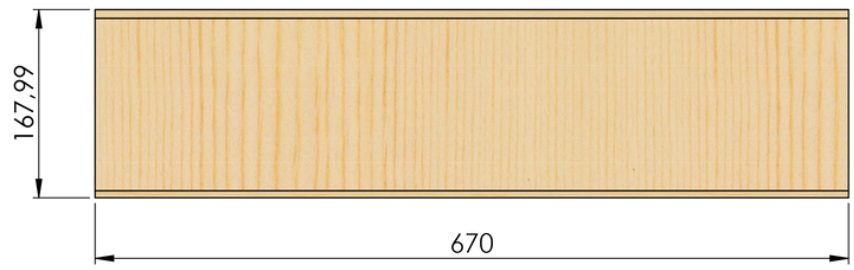



SIDE 4

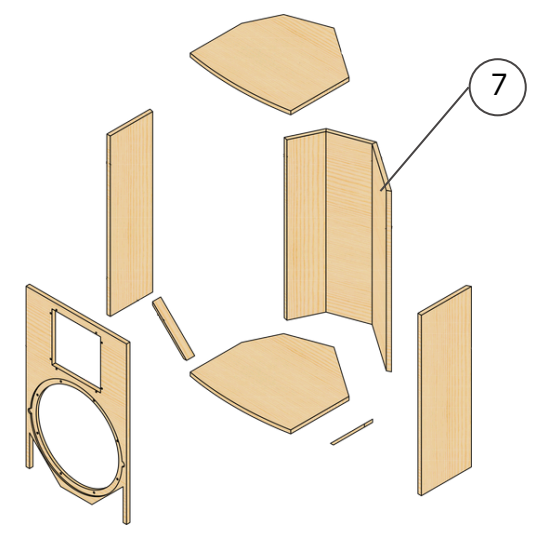
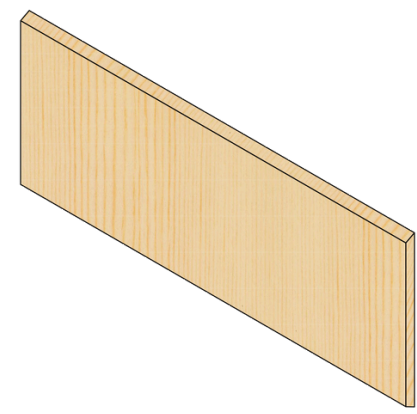
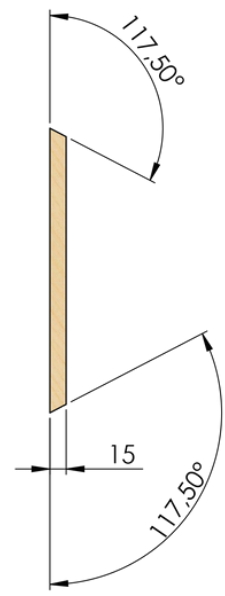



SIDE 5

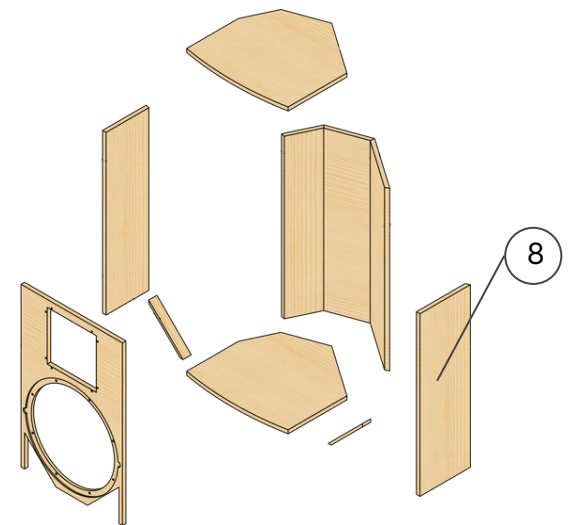
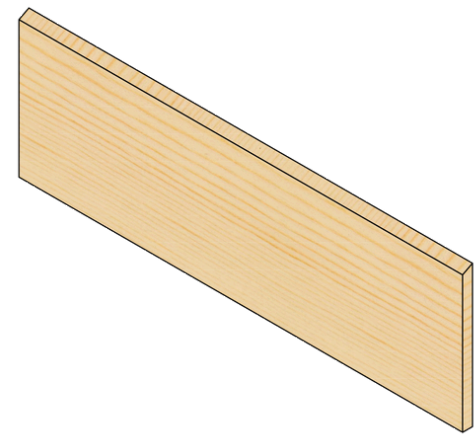
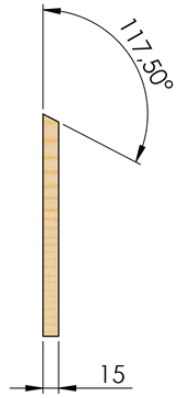
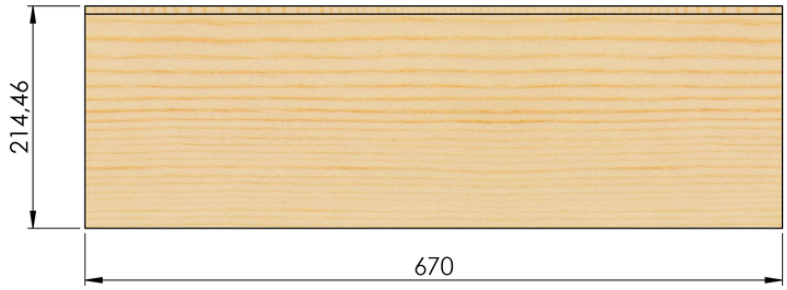

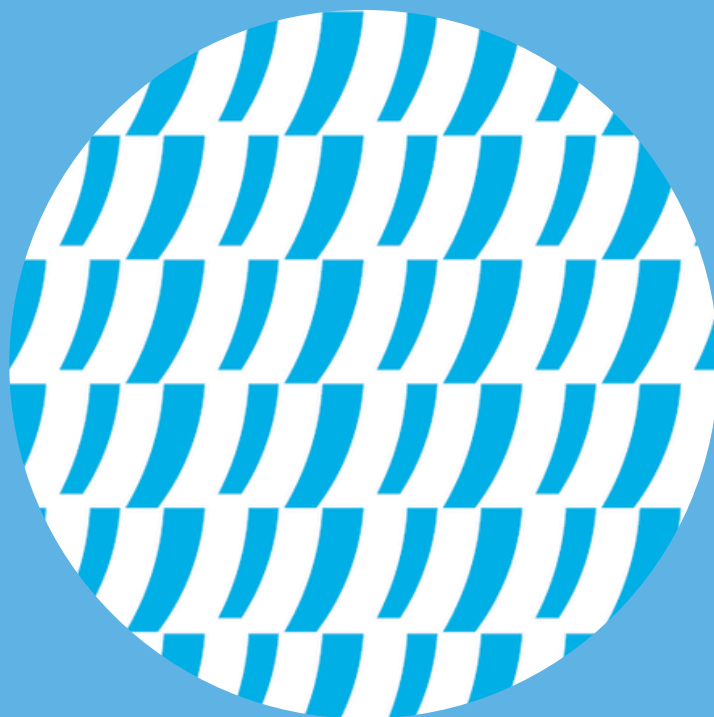

LET'S TALK

[www.beyma.com](http://www.beyma.com)