

FR-15MC HI

FULL RANGE 2 WAY SYSTEM 15"

15MC700Nd / 15MCB700

CD314Nd/Fe

TD-365



ENCLOSURE RECOMMENDED DESIGN

www.beyma.com



TECHNICAL SPECIFICATIONS

Frequency response (+/-3dB)	85Hz-18KHz
Usable bandwidth (-10dB)	60Hz-19KHz
Maximum SPL(*)	133,5dB
Sensitivity 1W@1m	99dB
HxV Coverage angle (-6dB)	60°x50° rotatable
Transducers LF	15MC700ND/MCB
Transducers HF	CD314Nd/Fe
AES Power Handling	700
Nominal impedance	8Ω
Connectors	2xNL4
Box dimmensions (**)	430 x 700 x 391.39 (Birch Plywood 15/9mm)

(*) Peak level at 1m under free field conditions usin pink noise with 6dB crest factor

(**) All dimmensions in millimeters



PRESSETS

FR-15MC HI	f(Hz)	Q	Gain(dB)
L-SH 12dB/oct	160	-	2,5
-	230	6,9	6,2
-	260	3,3	-5
-	1340	3	-2,4
	3700	3	-2
	5066	4	2
LIMITER	Thres (dBu)	Attack (ms)	Release (ms)
PEAK	10,7	8	128

* for 32dB gain amplifier
 * frequency response graph CD314Nd/Ti with TD365 horn

FREQUENCY RESPONSE

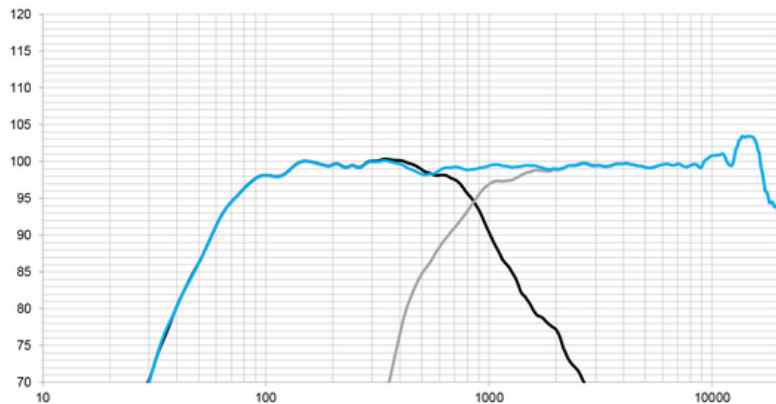

PASSIVE CROSSOVER DESIGN

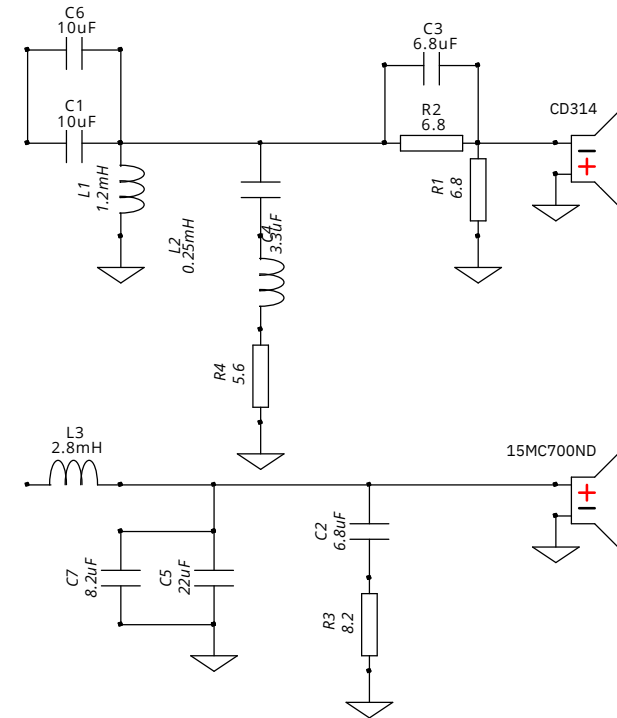

IMPEDANCE

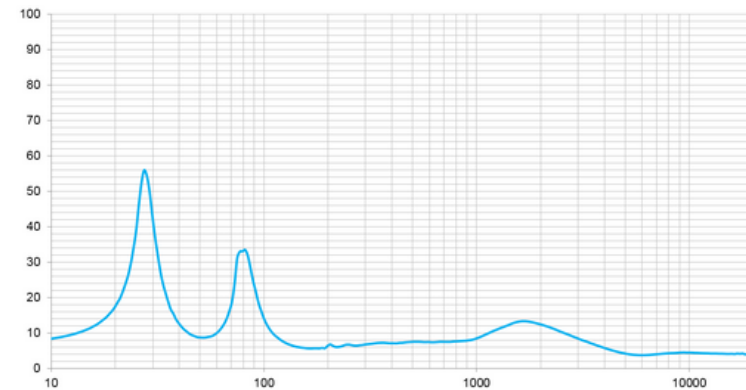



GENERAL VIEW WITH COMPONENTS

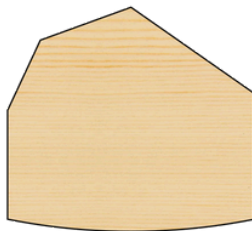
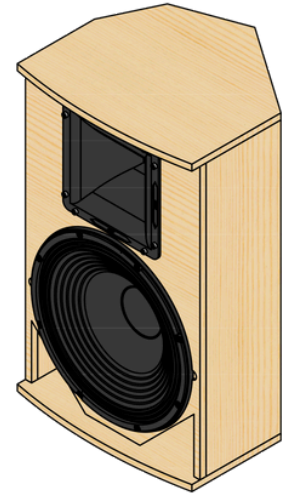
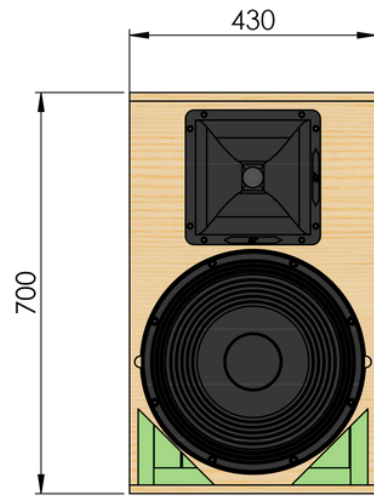



EXPLODED VIEW WITH COMPONENTS

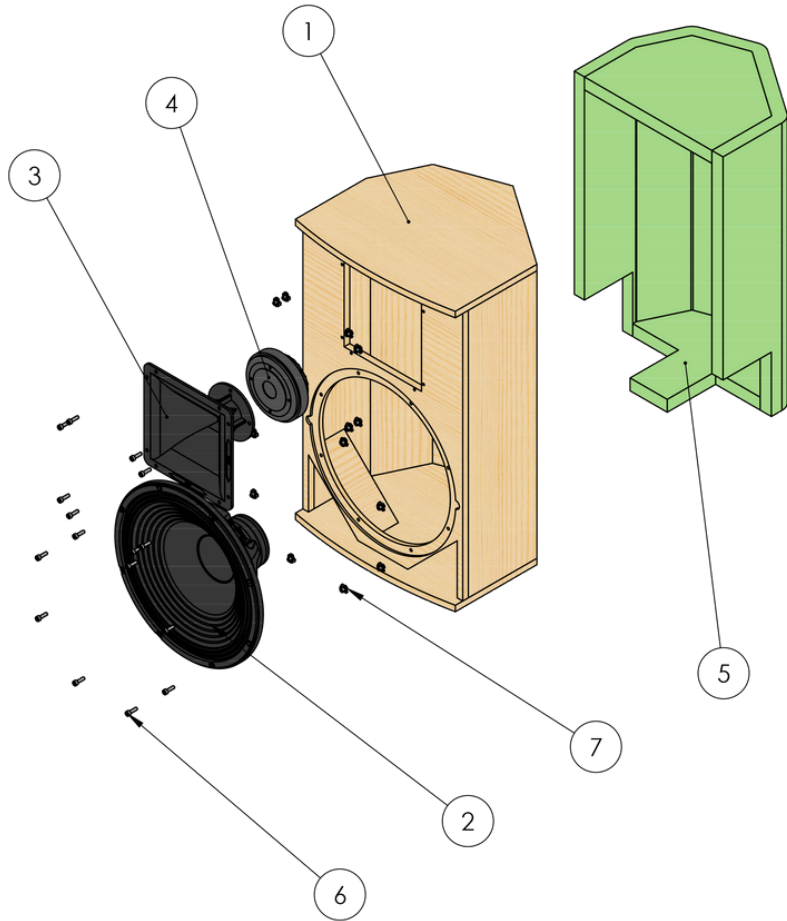

ELEMENT NUMBER	PIECE NUMBER	QUANTITY
1	FR-15MC HI	1
2	15MC700Nd / 15MCB700	1
3	TD365	1
4	CD314Nd/Fe	1
5	DAMPING MATERIAL	1
6	SCREW DIN 912 M6x20	16
7	NUT DIN1624 - M6	16



GENERAL VIEW

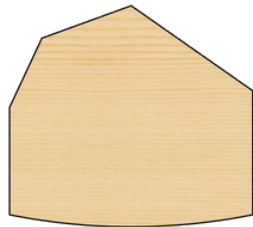
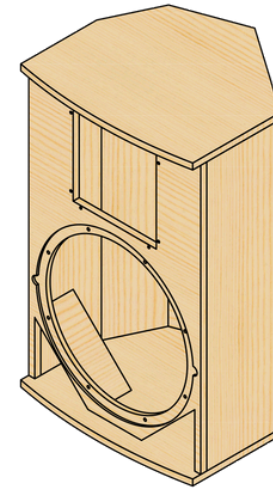
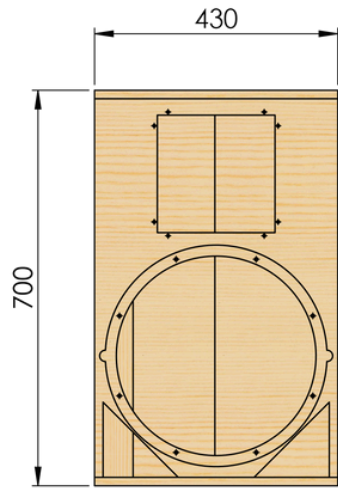



EXPLODED VIEW

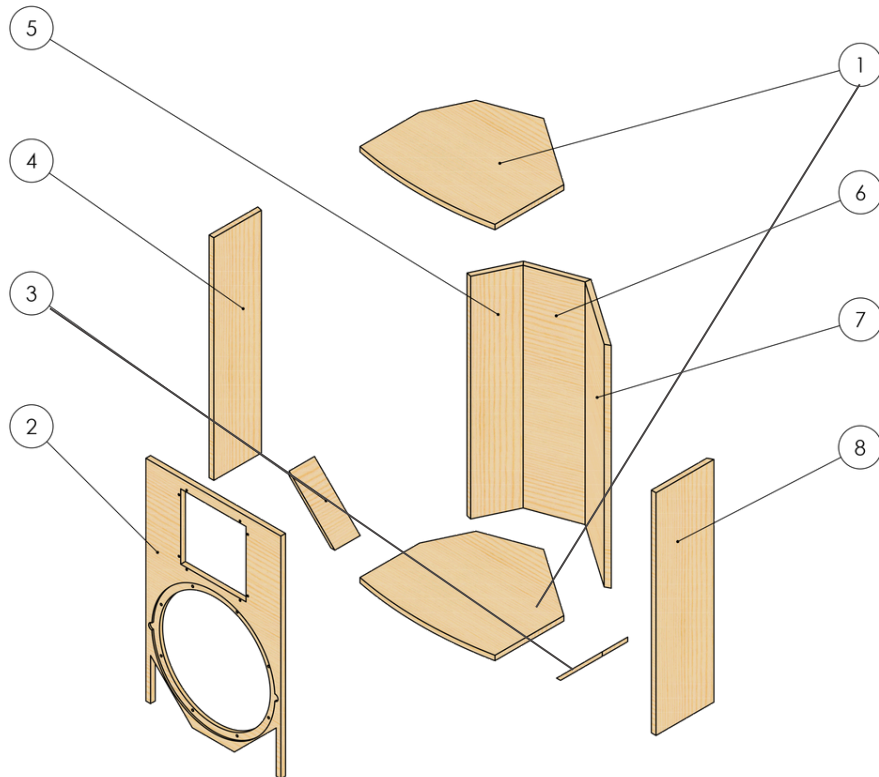
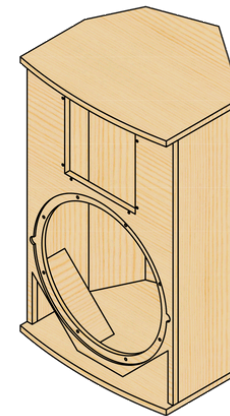

ELEMENT NUMBER	PIECE NUMBER	QUANTITY
1	TOP & BOTTOM PARTS	2
2	FRONT PANEL	1
3	REFLEX	2
4	SIDE_1	1
5	SIDE_2	1
6	SIDE_3	1
7	SIDE_4	1
8	SIDE_5	1



TOP & BOTTOM PARTS

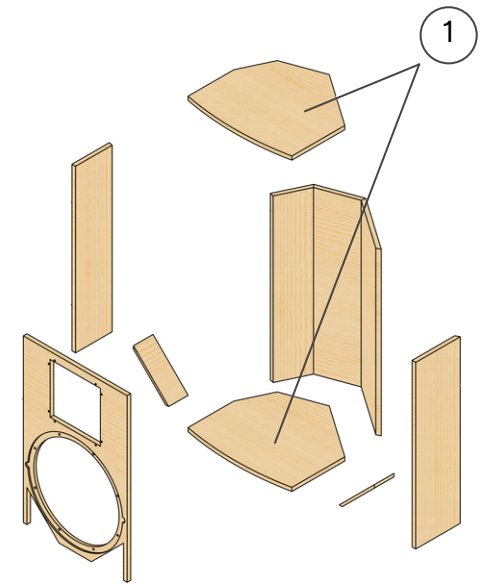
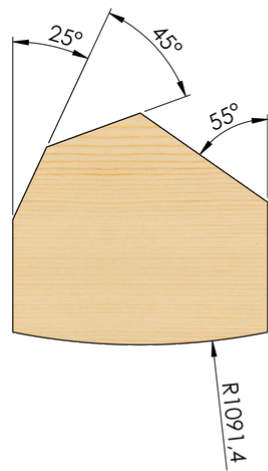
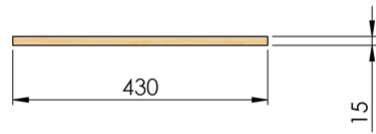
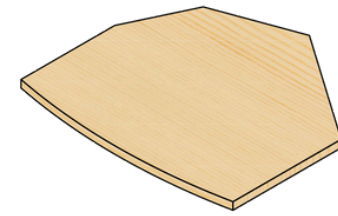
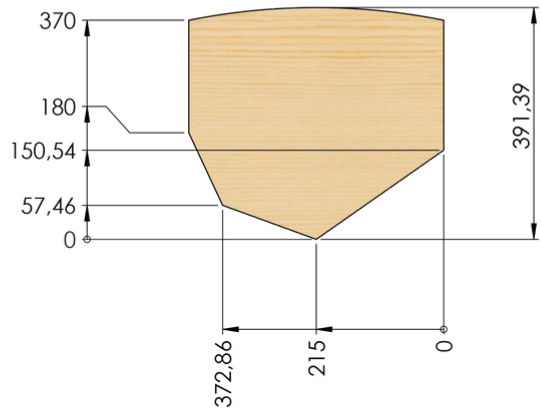



FRONT PANEL

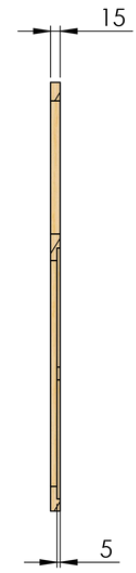
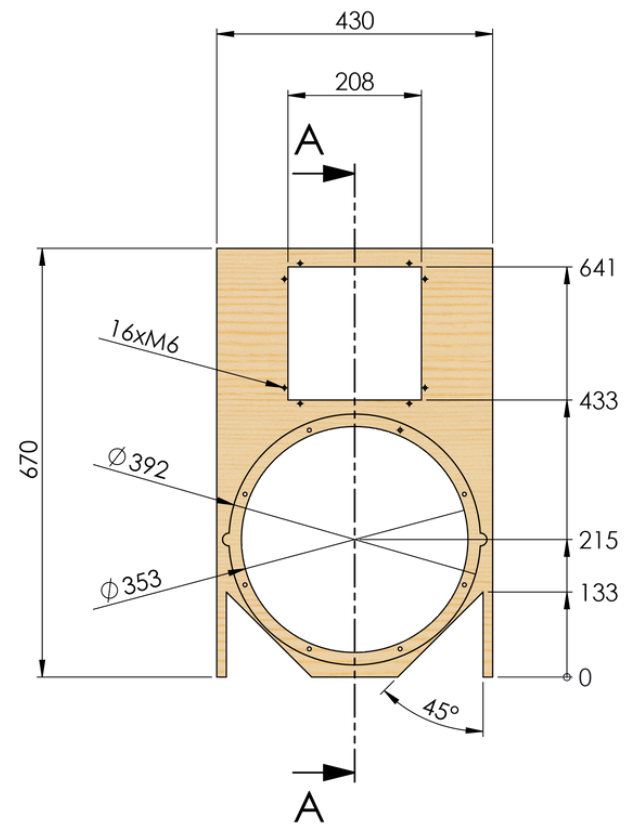

SECTION A-A

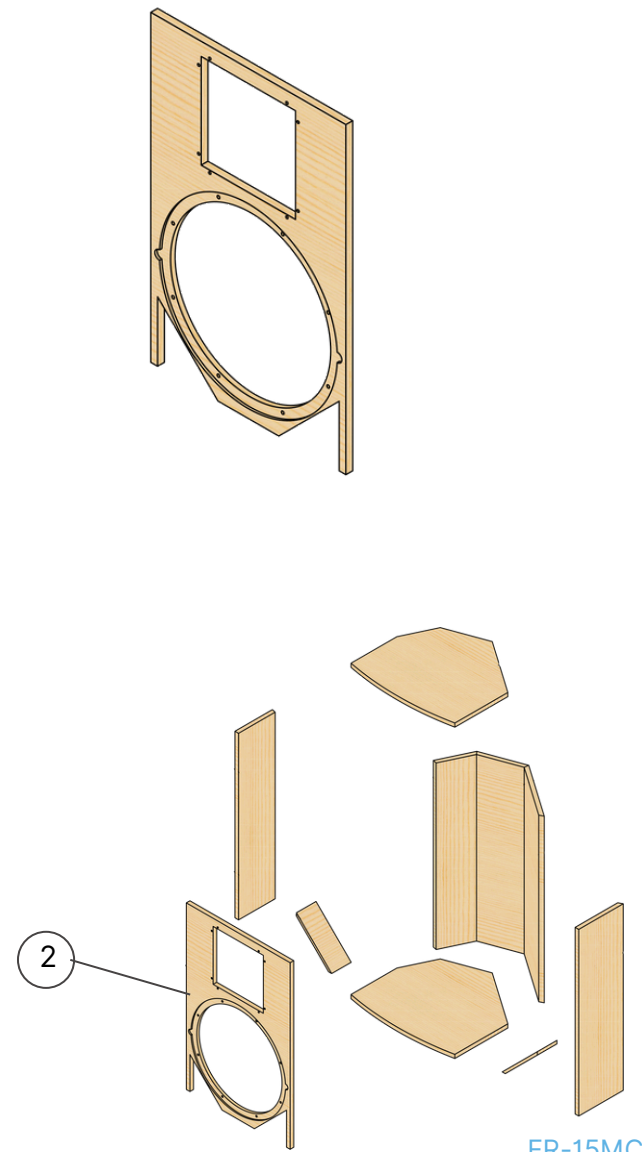



REFLEX

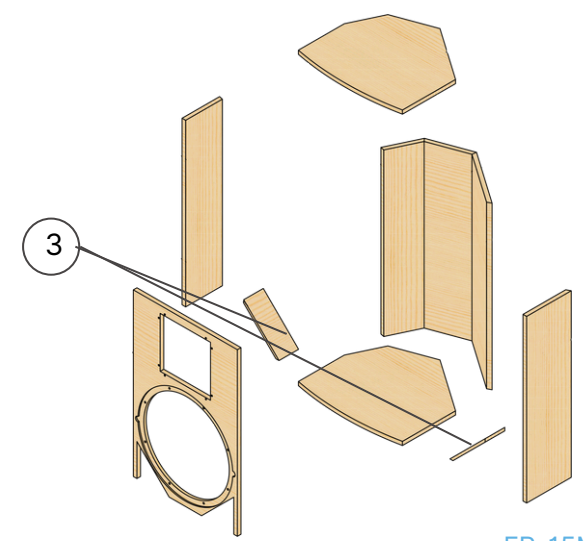
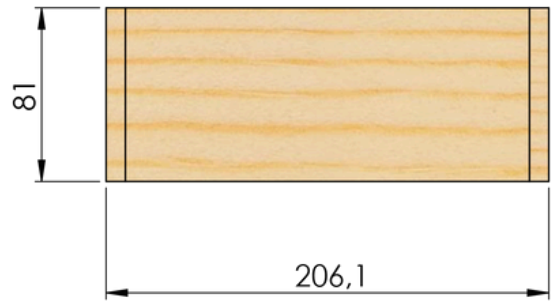
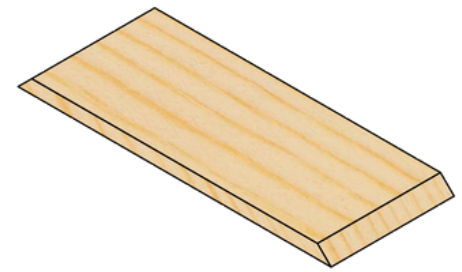
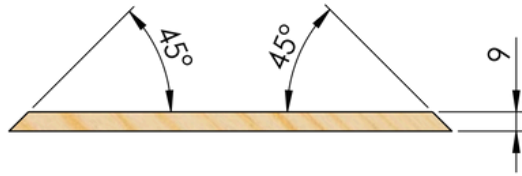



SIDE 1

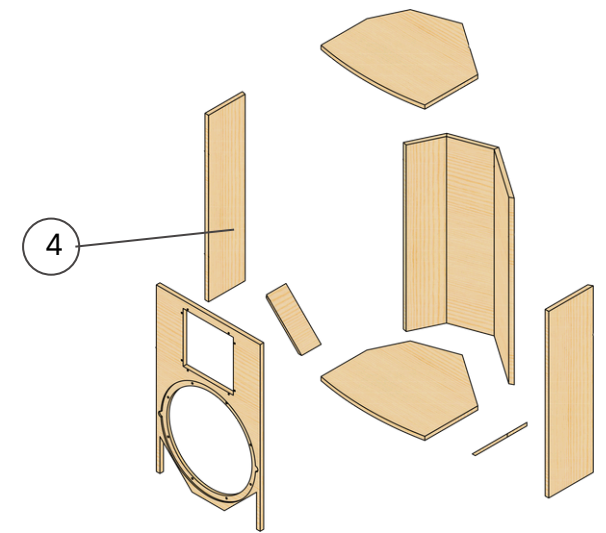
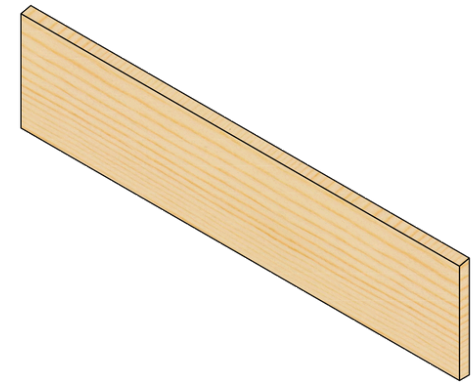
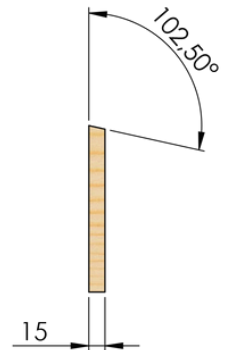



SIDE 2

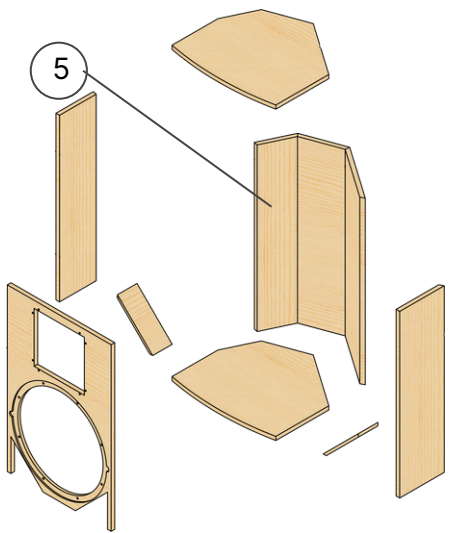
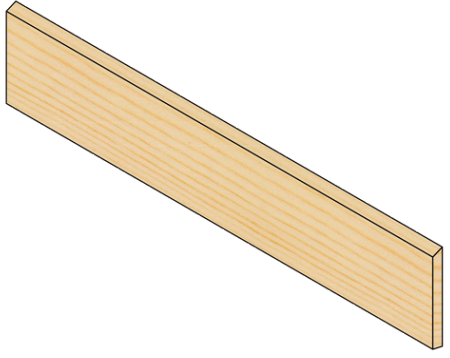
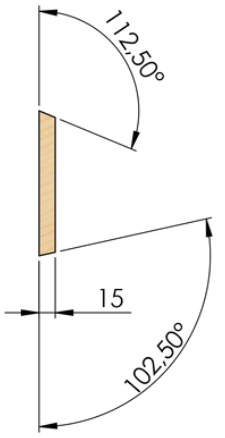



SIDE 3

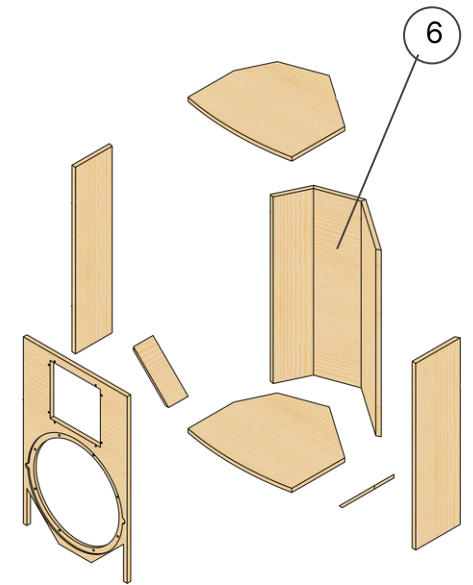
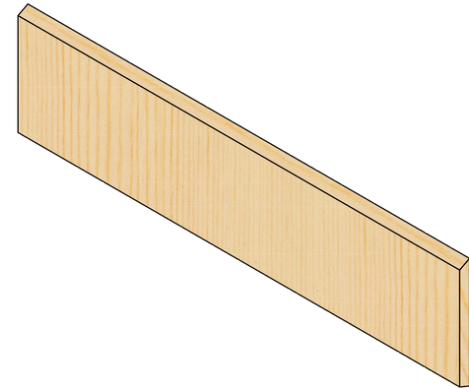
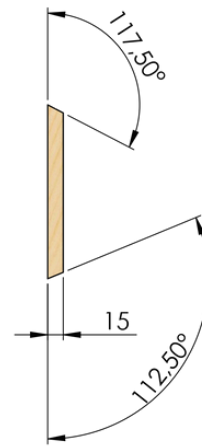
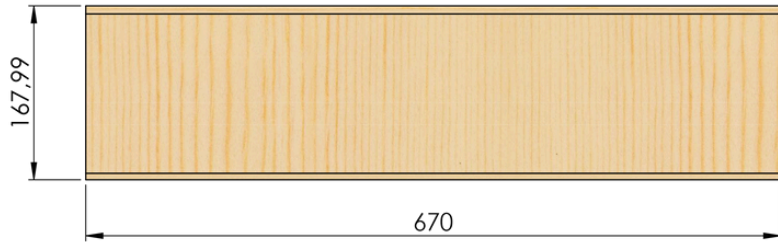



SIDE 4

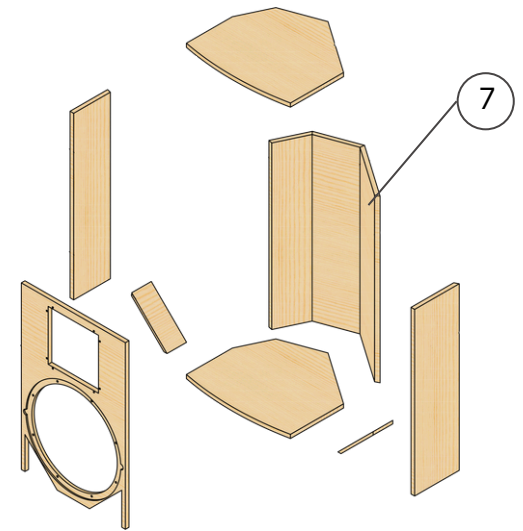
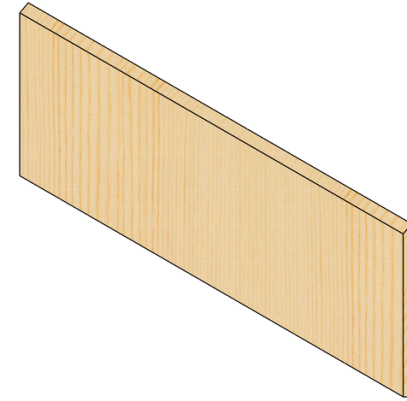
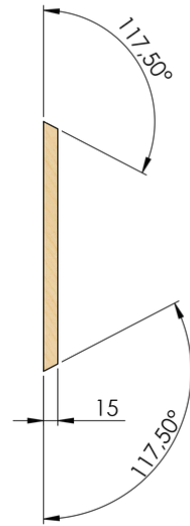
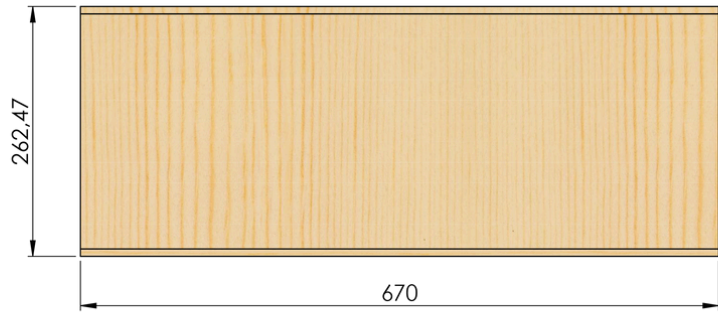



SIDE 5

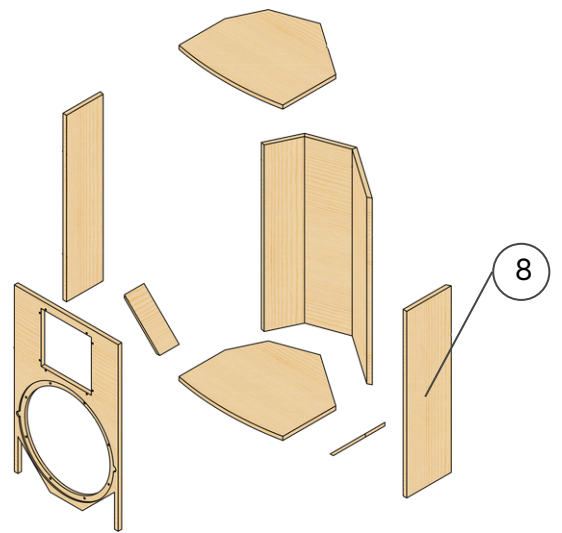
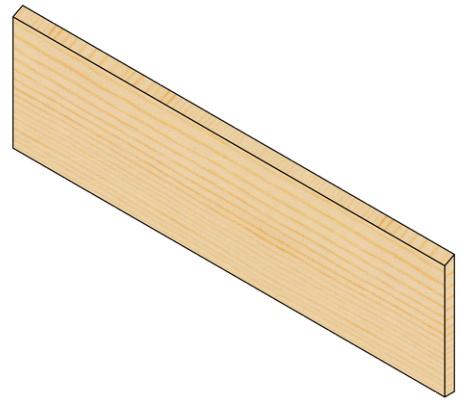
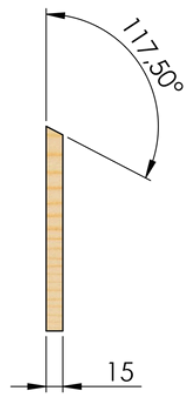
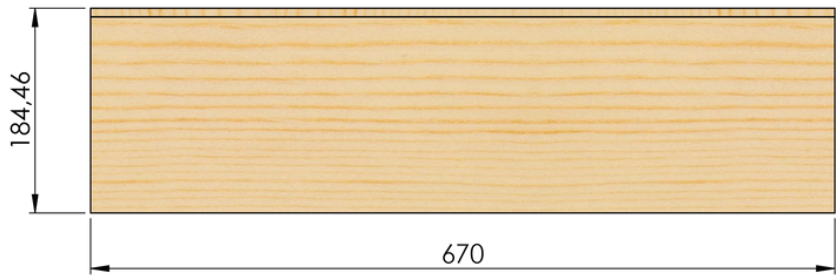

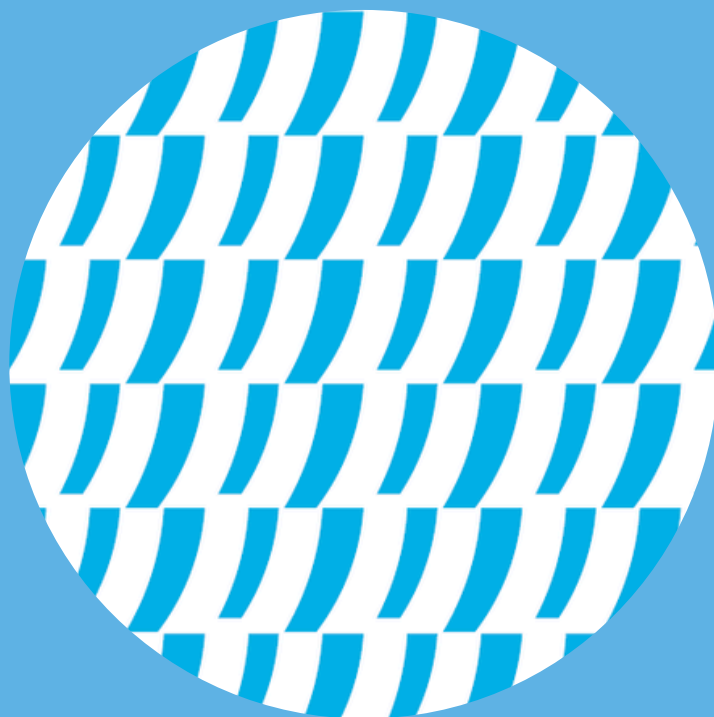

LET'S TALK

www.beyma.com